

DRAFT INTERNATIONAL STANDARD

ISO/DIS 19682

ISO/TC 136

Secretariat: UNI

Voting begins on:
2022-04-13

Voting terminates on:
2022-07-06

Furniture — Tables — Test methods for the determination of stability, strength and durability

Ameublement — Tables — Méthodes d'essai pour la détermination de la stabilité, de la résistance et de la résistance et de la durabilité

ICS: 97.140

THIS DOCUMENT IS A DRAFT CIRCULATED FOR COMMENT AND APPROVAL. IT IS THEREFORE SUBJECT TO CHANGE AND MAY NOT BE REFERRED TO AS AN INTERNATIONAL STANDARD UNTIL PUBLISHED AS SUCH.

IN ADDITION TO THEIR EVALUATION AS BEING ACCEPTABLE FOR INDUSTRIAL, TECHNOLOGICAL, COMMERCIAL AND USER PURPOSES, DRAFT INTERNATIONAL STANDARDS MAY ON OCCASION HAVE TO BE CONSIDERED IN THE LIGHT OF THEIR POTENTIAL TO BECOME STANDARDS TO WHICH REFERENCE MAY BE MADE IN NATIONAL REGULATIONS.

RECIPIENTS OF THIS DRAFT ARE INVITED TO SUBMIT, WITH THEIR COMMENTS, NOTIFICATION OF ANY RELEVANT PATENT RIGHTS OF WHICH THEY ARE AWARE AND TO PROVIDE SUPPORTING DOCUMENTATION.

This document is circulated as received from the committee secretariat.



Reference number
ISO/DIS 19682:2022(E)

© ISO 2022



COPYRIGHT PROTECTED DOCUMENT

© ISO 2022

All rights reserved. Unless otherwise specified, or required in the context of its implementation, no part of this publication may be reproduced or utilized otherwise in any form or by any means, electronic or mechanical, including photocopying, or posting on the internet or an intranet, without prior written permission. Permission can be requested from either ISO at the address below or ISO's member body in the country of the requester.

ISO copyright office
CP 401 • Ch. de Blandonnet 8
CH-1214 Vernier, Geneva
Phone: +41 22 749 01 11
Email: copyright@iso.org
Website: www.iso.org

Published in Switzerland

Table of Contents

1	Scope	1
2	Normative references	1
3	Terms and definitions	1
4	General test condition	2
4.1	Preliminary preparations	2
4.2	Application of forces.....	3
4.3	Tolerances.....	3
5	Test Equipment and Apparatus	3
6	Test procedures – Strength and durability	6
6.1	General	6
6.2	Horizontal static load test	6
6.3	Vertical static load tests.....	13
6.3.1	Vertical static load on main surface.....	13
6.3.2	Additional vertical static load test where the main surface has a length > 1600 mm.....	14
6.3.3	Vertical static load on end extension	15
6.4	Horizontal durability and stiffness test.....	16
6.4.1	General.....	16
6.4.2	Horizontal durability test.....	16
6.4.3	Stiffness of the structure	20
6.5	Vertical durability test.....	23
6.6	Vertical impact test.....	23
6.6.1	General.....	23
6.6.2	Vertical impact test for glass table tops.....	23
6.6.3	Vertical impact test for all other table tops	23
6.7	Deflection of table tops.....	24
6.8	Durability of tables with castors.....	24
6.9	Drop test	25
6.10	Table Top-to-Leg Assembly Strength.....	26
7	Test procedures – Stability	29
7.1	General	29
7.2	Stability under vertical load	29
7.2.1	General.....	29
7.2.2	Test for tables that are or can be set to a height of 950 mm or less.....	30
7.2.3	Test for tables that are or can be set to a height greater than 950 mm.....	30
7.3	Stability for tables with extension elements (drawers).....	31
7.4	Stability of tables designed to support a parasol.....	31
7.5	Horizontal Stability Test	32
7.6	Force Stability Test for Tall Products.....	34
8	Test procedures – Height adjustment mechanism	35
8.1	General	35
8.2	Durability of Height adjustment mechanism	36
9	Tilting Top Table - Cycle Test	38
9.1	Test Setup.....	38
9.2	Test Procedure	38

9.3	Acceptance Level.....	38
10	Tilting Top Table - Latch Strength Test.....	40
10.1	Test Setup	40
10.2	Test Procedure.....	40
10.3	Acceptance Level.....	40
11	Test Report Format	42
Annex A	informative Recommendations.....	43
A.1	Principle	43
A.2	General Requirements.....	43
A.3	Test Level in Relations to Field of Application.....	46
Annex B	informative Purpose and Applicability	47

Foreword

ISO (the International Organization for Standardization) is a worldwide federation of national standards bodies (ISO member bodies). The work of preparing International Standards is normally carried out through ISO technical committees. Each member body interested in a subject for which a technical committee has been established has the right to be represented on that committee. International organizations, governmental and non-governmental, in liaison with ISO, also take part in the work. ISO collaborates closely with the International Electrotechnical Commission (IEC) on all matters of electrotechnical standardization.

The procedures used to develop this document and those intended for its further maintenance are described in the ISO/IEC Directives, Part 1. In particular, the different approval criteria needed for the different types of ISO documents should be noted. This document was drafted in accordance with the editorial rules of the ISO/IEC Directives, Part 2 (see www.iso.org/directives).

Attention is drawn to the possibility that some of the elements of this document may be the subject of patent rights. ISO shall not be held responsible for identifying any or all such patent rights. Details of any patent rights identified during the development of the document will be in the Introduction and/or on the ISO list of patent declarations received (see www.iso.org/patents).

Any trade name used in this document is information given for the convenience of users and does not constitute an endorsement.

For an explanation of the voluntary nature of standards, the meaning of ISO specific terms and expressions related to conformity assessment, as well as information about ISO's adherence to the World Trade Organization (WTO) principles in the Technical Barriers to Trade (TBT), see www.iso.org/iso/foreword.html.

This document was prepared by Technical Committee ISO/TC 136, Furniture.

This document is intended to cancel and replace ISO 21016:2007 Office furniture – Tables and desks – Test methods. This new document will be broader in scope beyond only Office furniture. This document is a proposal for test methods for stability, strength and durability for table and desk furniture.

Any feedback or questions on this document should be directed to the user's national standards body. A complete listing of these bodies can be found at www.iso.org/members.html.

Safety aspects (e.g. resistance to heat and electric shock) of electrically motorized furniture are additionally covered by IEC 60335-2-116.

Introduction

Members of Technical Committee 136 for Furniture are not aware of any patent claims relating to the use of this standard.

Furniture — Tables — Test methods for the determination of stability, strength and durability

1 Scope

This International Standard specifies test methods for the determination of stability, strength and durability of the structure of all types of tables and desks without regard to use, materials, design/construction or manufacturing process.

Other methods for determination of the strength and durability of storage components, seating surfaces, and other features which may be incorporated into tables are covered by other standards.

This International Standard does not apply to baby changing units.

Tests carried out according to these test methods are intended to demonstrate the ability of the item to give satisfactory service in its intended environment. The tests have been developed for units/components that have not been in use. However, when properly justified, they can be used for fault investigation.

This standard does not cover test methods for the assessment of ageing, degradation, flammability or electrical components.

This International Standard specifies test methods only. It does not specify requirements. These should be specified in a requirements document. If this is not available, suggested loads and cycles can be found in Annex A. It is up to the specifier to determine which tests are appropriate.

2 Normative references

The following documents are referred to in the text in such a way that some or all of their content constitutes requirements of this document. For dated references, only the edition cited applies. For undated references, the latest edition of the referenced document (including any amendments) applies.

ISO 7170:2021, *Furniture – Storage units — Test methods for the determination of strength, durability and stability*

ISO 48-4, *Rubber, vulcanized or thermoplastic — Determination of hardness — Part 4: Indentation hardness by durometer method (Shore hardness)*

3 Terms and definitions

For the purposes of this document, the following terms and definitions apply. ISO and IEC maintain terminological databases for use in standardization at the following addresses:

- IEC Electropedia: available at <http://www.electropedia.org/>
- ISO Online browsing platform: available at <http://www.iso.org/obp>

3.1

adjustable leg

table leg with more than 40 mm of vertical range (see 3.4)

3.2

duty cycle

length of time the height adjustable table's drive system may be operated without impairing its useful life

3.3

end extension

added surface beyond the original surface that is not directly supported by the floor and adds 200 mm or greater to an end

3.4

levelling device

device whose primary function is to keep the table top horizontal e.g. adjustable feet or similar with a limitation of 40 mm of vertical range (see 3.1)

3.5

main surface

all surfaces that are not a shelf

3.6

safety glass

glass with additional features that make it less likely to break, or less likely to pose a threat when broken

3.7

secondary surface

surface such as a shelf that is vertically separated from, and smaller than, the main surface(s) and used for storage or occupied exclusively by the equipment placed on the surface

3.8

structure

load bearing parts of furniture such as the frame, top and legs

3.9

type 1 tables

tables having a main surface 600 mm or more above the floor surface and a surface area greater than 0,50 square meters

3.10

type 2 tables

all tables that do not meet the definition of Type 1 tables

4 General test condition

4.1 Preliminary preparations

The furniture shall be tested as delivered. Knock-down furniture shall be assembled according to the instructions supplied with it. If the instructions allow the furniture to be assembled or combined in different ways, the most adverse combination shall be used for each test. Knock-down fittings shall be tightened before testing. Further tightening shall not take place unless specifically required by the manufacturer.

During testing, the unit shall be placed on the floor and leveled, unless otherwise specified. Levelling devices shall be set to the mid position but not more than 13 mm from fully closed.

Products with adjustable features shall be set at their most adverse position for testing unless otherwise specified.

Unless otherwise specified by the manufacturer, the sample for test shall be stored in indoor ambient conditions for at least 24 h immediately prior to testing. The tests shall be carried out at indoor ambient conditions but if during a test the temperature is outside the range 15 °C to 27 °C the maximum and/or minimum temperature shall be recorded in the test report. The test for deflection of table tops (see 6.7), except those made from metal, glass and stone, shall be carried out at a relative humidity of 45 % to 55 %. If during a test the relative humidity is outside of the range of 45 % to 55 %, the maximum and/or minimum humidity shall be recorded in the test report.

If a test cannot be carried out as specified, e.g. because a loading pad cannot be used for the application of a force due to the design of a product, the test shall be carried out as closely as possible to that specified. Any modification to the test method shall be technically justified and shall be recorded in the test report.

Before beginning the testing, visually inspect the unit thoroughly. Record any defects so that they are not assumed to have been caused by the tests. Carry out measurements, if specified.

It is not necessary that all tests be carried out on the same unit, but all tests specified for a particular component shall be carried out on the same component.

4.2 Application of forces

The test forces in durability and static load tests shall be applied sufficiently slowly to ensure that negligible dynamic load is applied. Unless otherwise specified, each specified force shall be maintained for not less than 10 s and not more than 15 s. The forces in durability tests shall be applied sufficiently slowly to ensure that kinetic heating does not occur. Unless otherwise stated, durability loads shall be maintained for (2 ± 1) s.

Forces shall be applied in a manner which ensures normal functioning of self-closing and damping mechanisms.

The forces may be replaced by masses. The relationship $10 \text{ N} = 1 \text{ kg}$ shall be used.

4.3 Tolerances

Unless otherwise stated, the following tolerances are applicable to the test equipment:

Forces: $\pm 5 \%$ of the nominal force;

Velocities: $\pm 5 \%$ of the nominal velocity;

Masses: $\pm 1 \%$ of the nominal mass;

Dimensions: $\pm 1 \text{ mm}$ of the nominal dimension; except loading pads $\pm 5 \text{ mm}$ of the nominal dimension. For dimensions greater than 200 mm, the tolerance shall be $\pm 0,5\%$ of the dimension.

Angles: $\pm 2\sigma$ of the nominal angle.

The accuracy for the positioning of loading pads and impact plates shall be $\pm 5 \text{ mm}$.

Test weights, forces, dimensions, angles, times, rates and velocities used to perform the tests shall be targeted at the nominal values specified.

NOTE For the purposes of uncertainty measurement, test results are not considered to be adversely affected when the above tolerances are met.

5 Test Equipment and Apparatus

Unless otherwise stated, the tests may be applied by any suitable device because the results are not dependent upon the apparatus, except in the case of impact tests where the apparatus described in 5.1 shall be used.

The equipment shall not inhibit deformation nor cause unnatural deformation of the unit/component, i.e. it shall be able to move so that it can follow the deformation of the unit/component during testing.

With the exception of the horizontal static, durability and stiffness tests, described in 6.2 and 6.4, all loading pads shall be capable of pivoting in relation to the direction of the applied force and the pivot point shall be as close as practically possible to the load surface.

Loading pads for the horizontal static, durability and stiffness tests, described in 6.2 and 6.4, shall not pivot.

With the exception of the horizontal static, durability and stiffness tests described in 6.2 and 6.4, if a loading pad tends to slide, use a slip resistant material between the loading pad and the surface being tested.

5.1 Vertical impactor, as shown in Figure 1 and comprised of the following:

5.1.1 Circular body, 200 mm in diameter separated from the striking surface by helical compression springs and free to move relative to it on a line perpendicular to the plane of the central area of the striking surface.

The body and associated parts minus the springs shall have a mass of $(17 \pm 0,1)$ kg and the whole apparatus, including mass, springs and striking surface, shall have a mass of $(25 \pm 0,1)$ kg.

5.1.1 Springs, which shall be such that the nominal spring rate of the combined spring system is (7 ± 2) N/mm and the total friction resistance of the moving parts is less than 1 N.

The spring system shall be compressed to an initial load of $(1\ 040 \pm 5)$ N (measured statically) and the amount of spring compression movement available from the initial compression point to the point where the springs become fully closed shall be not less than 60 mm.

5.1.2 Striking surface, which shall be a rigid circular object, 200 mm in diameter, the face of which has a convex spherical curvature of 300 mm radius with a 12 mm front edge radius.

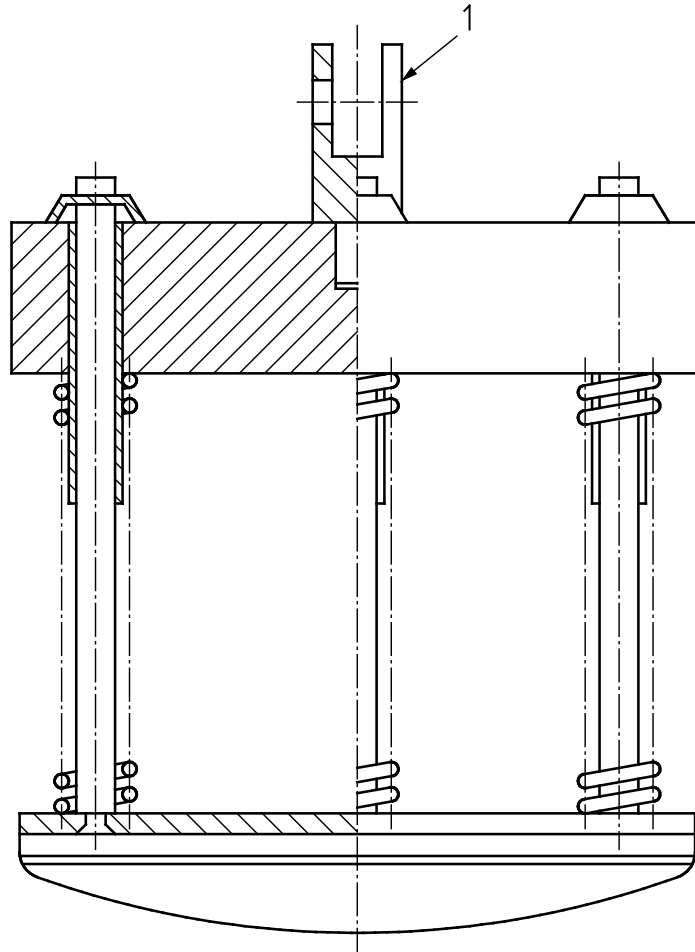

Key

- 1 joint of lifting device not inhibiting free fall

Figure 1 — Vertical impactor

5.2 Floor, horizontal, flat and rigid with a smooth surface.

For the drop test (6.9) the floor shall be faced with a 2 mm thick layer of rubber with a hardness of 85 ± 15 IRHD according to ISO 48-4.

5.3 Stops, to prevent the article from sliding but not tilting, no higher than 12 mm except in cases where the design of the item necessitates the use of higher stops.

5.4 Loading pad, a rigid cylindrical object, 100 mm in diameter, with a flat, smooth face and a 12 mm edge radius.

5.5 Foam, 25 mm thick layer of flexible foam with a bulk density of (120 ± 25) kg/m³.

5.6 Steel test tube, $(18 \pm 1,5)$ mm in diameter and $(1,5 \pm 0,5)$ mm in wall thickness with a length such that a force can be applied at a distance of 2 200 mm above the floor.

5.7 Test surface for castor durability test, horizontal, flat smooth and rigid steel surface.

5.8 Obstacles for castor durability test, steel strips 50 mm wide and 3,2 mm high with the top edges having a radius of 3,2 mm, 500 mm apart and parallel on the floor surface and perpendicular to the test direction.

5.9 Test foam for glass - a foam sheet with a thickness of 100 mm, a bulk density of (35 ± 5) kg/m³ and an indentation hardness index of (170 ± 40) N HA (40 %/30 s) in accordance with EN ISO 2439.

6 Test procedures – Strength and durability

6.1 General

Unless otherwise specified, the tests shall be carried out in the configuration most likely to cause failure.

NOTE There may be multiple configurations likely to cause failure. Multiple test configurations may be required.

Where the table top can be extended or enlarged, then the extended configuration shall be considered most likely to cause failure and tested as extended unless specified otherwise. In this case, the extended configuration is considered to be the main surface except for end extensions.

If a test cannot be carried out as specified, the test shall be carried out as closely as possible to that specified. Any modification to the test method shall be technically justified and shall be recorded in the test report.

If a table has storage components (secondary surfaces), then all the applicable tests in this standard shall be conducted, unless specified otherwise, by using the loads per Table 1 of ISO 7170:2021 *Furniture – Storage units – Test methods for the determination of strength, durability and stability*.

6.2 Horizontal static load test

Position the table on the test surface, in its normal position of use without extending end extensions.

Height adjustable tables shall be set to their highest position, but not to exceed 950 mm. Restrain the base of the table by stops placed in all directions at the opposite end to that at which the horizontal test force is first to be applied.

Apply a 50 kg mass to an area of (300 ± 50) mm x (300 ± 50) mm, or a diameter of (300 ± 50) mm, to the approximate centre of the table top. See figure 2 for recommended examples of load placement.

NOTE For Type 2 tables, apply the 50 kg mass or manufacturers recommended maximum but no less than 25 kg.

For vertical flat edge tops (no profile-edge), apply the specified horizontal force by means of a loading pad (5.4) centred within 10 mm of the table top level (see figure 3) in a direction perpendicular to a line

joining the two legs/supports, midway between the legs/supports of the side of the applied force. See Figures 2a, 2c, 2e, 2g and 2i. For tops without a vertical edge (profile-edge), apply the load with the loading pad centred at the outermost edge even if more than 10 mm from the top (see Figure 3).

If the table top is not secured to the understructure and the top moves when the specified force is applied, reduce the force sufficiently to just prevent movement. Record the force applied. The applied force shall not be reduced below the specified minimum force.

If the unrestrained portion of the base lifts when the specified force is applied, reduce the force sufficiently to just prevent lifting. Record the force applied. The applied force shall not be reduced below the specified minimum force. If unrestrained portion of the base lifts at this force, the specified mass applied to the table top shall be increased gradually until this tendency ceases.

Leaving the stops in position, use the same procedure to determine the force to be applied in the opposite direction.

One application of the force in each direction represents one cycle. Repeat the load application for a total of 10 cycles.

Repeat the test method applying the specified horizontal force at the work top level along the line joining the two legs/supports. See Figures 2b, 2d, 2f, 2h and 2j.

Apply the same force in the opposite direction.

One application of the force in each direction represents one cycle. Repeat the load application for a total of 10 cycles.

Repeat this procedure until each unique leg design/construction has been tested.

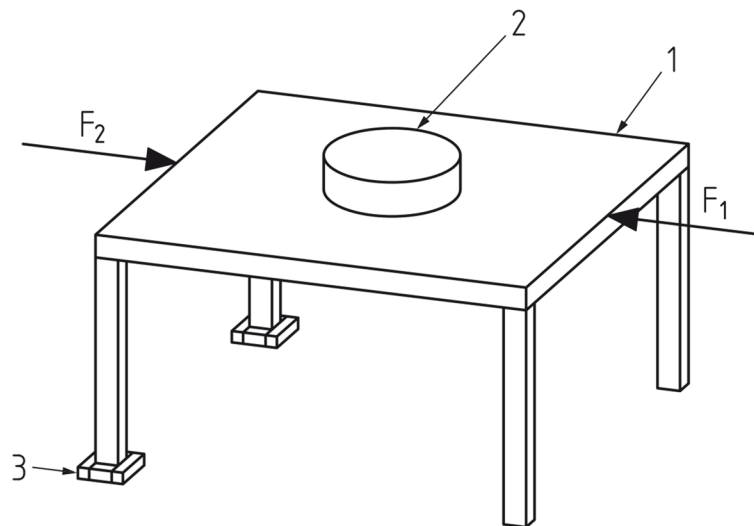

a) Rectangular table – first and second directions

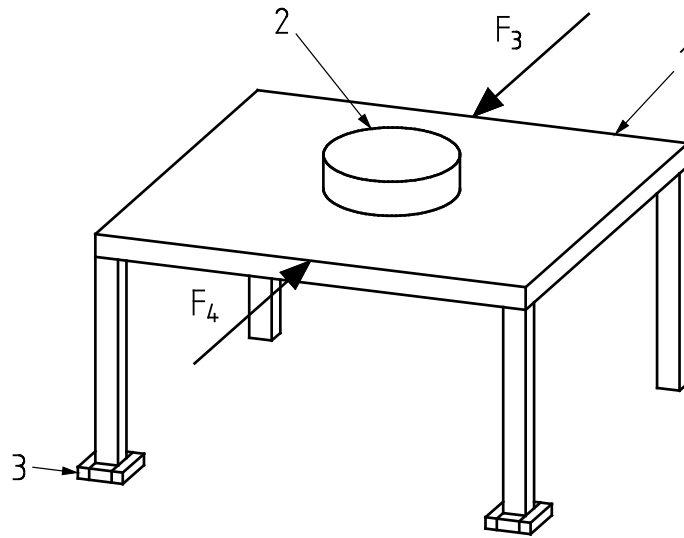

b) Rectangular table - third and fourth directions

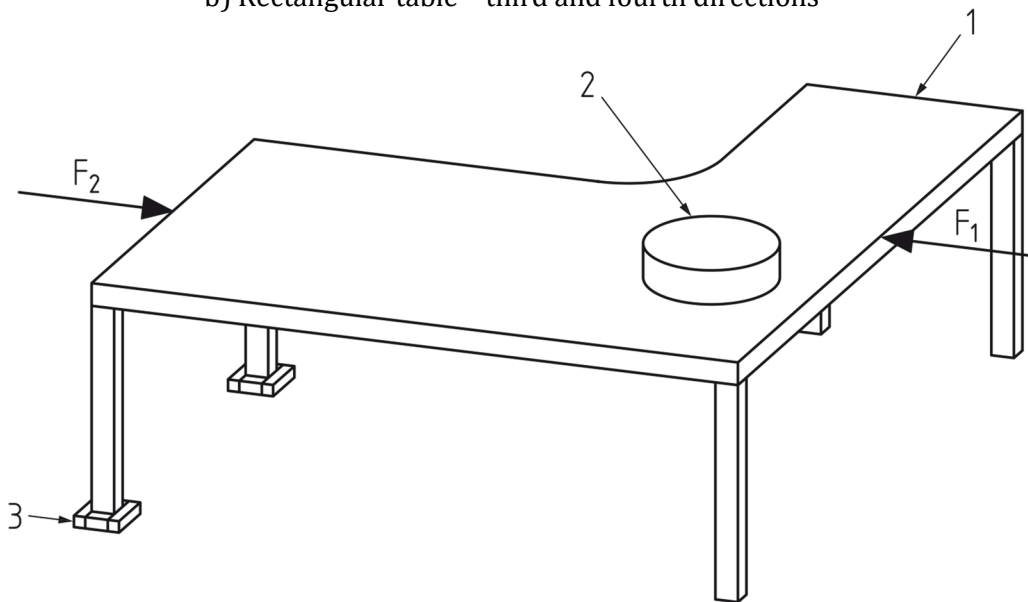

c) Irregular shape table - first and second directions

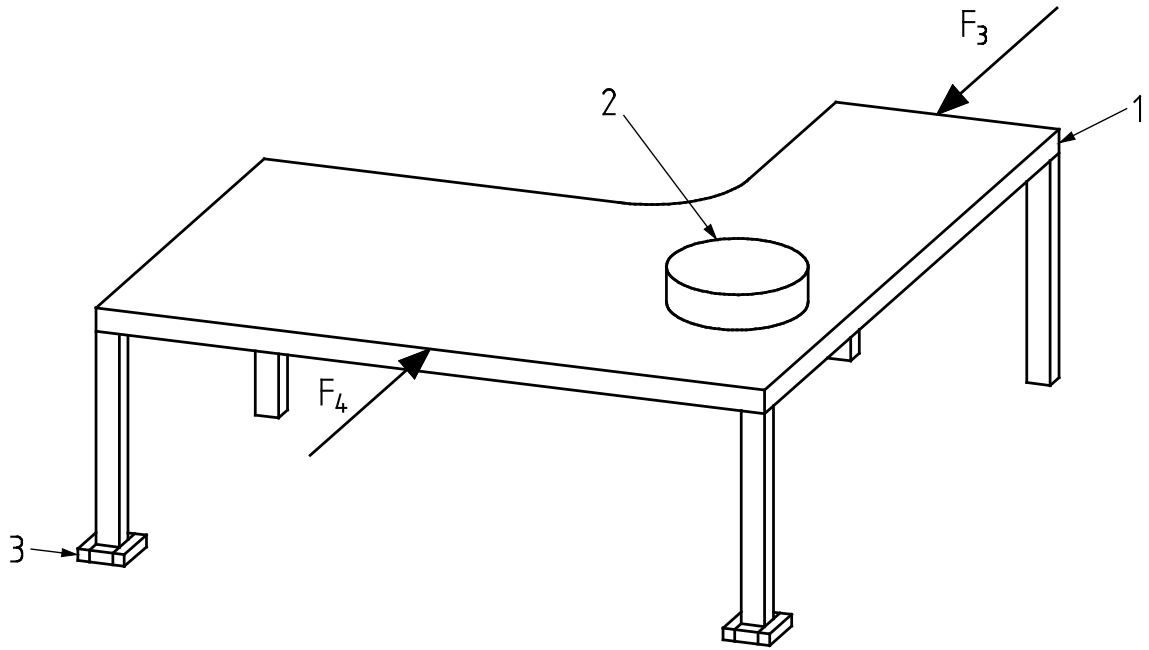

d) Irregular shape table - third and fourth directions

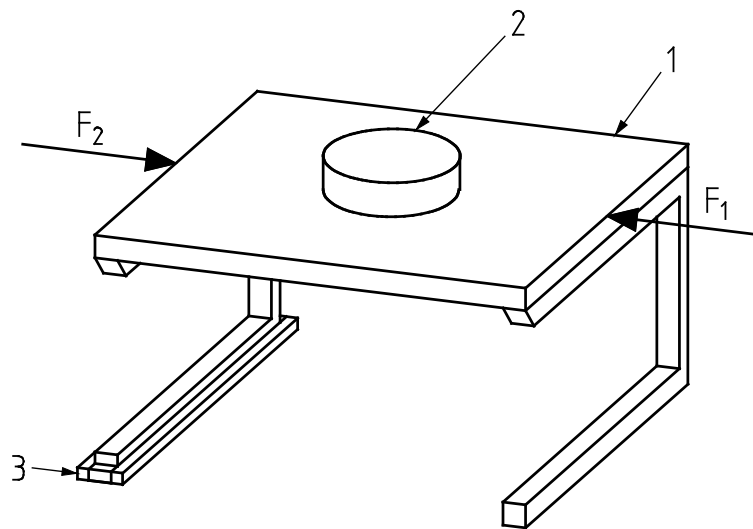

e) Cantilever table – first and second directions

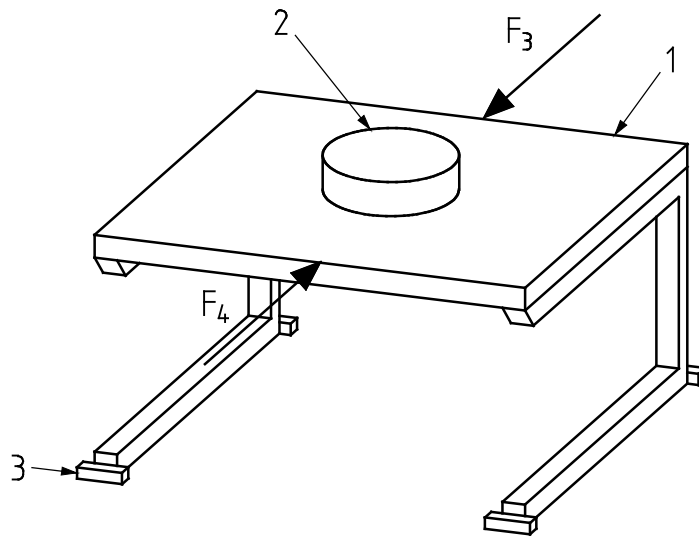

f) Cantilever table – third and fourth directions

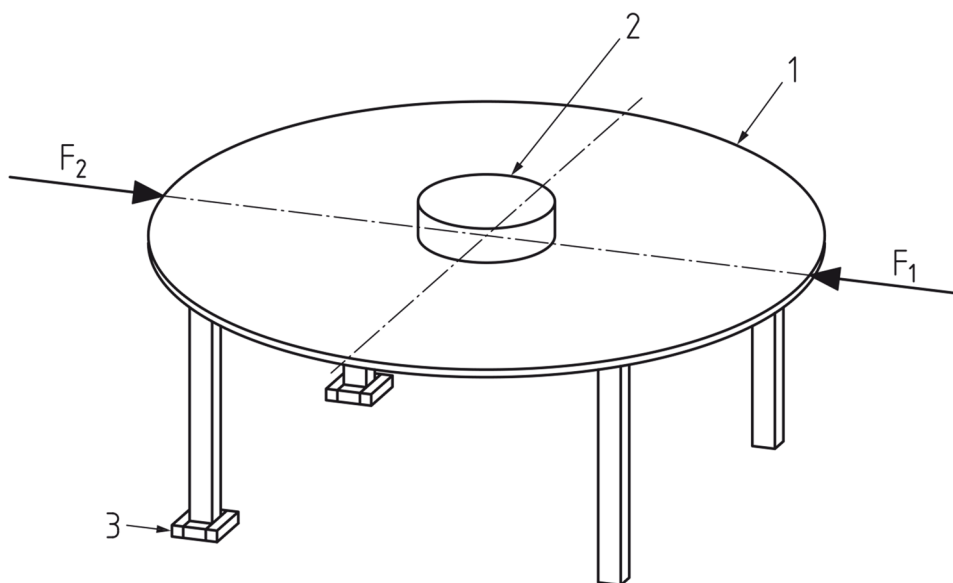

g) Oval/round table – first and second directions

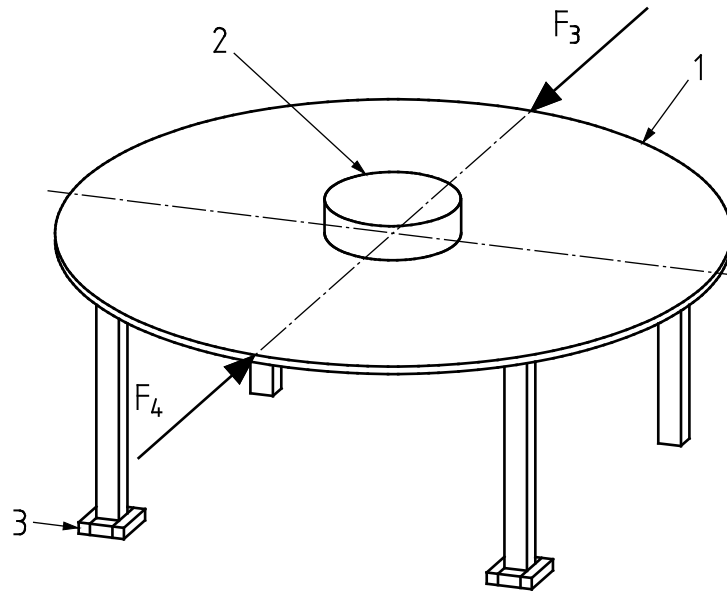

h) Oval/round table – third and fourth directions

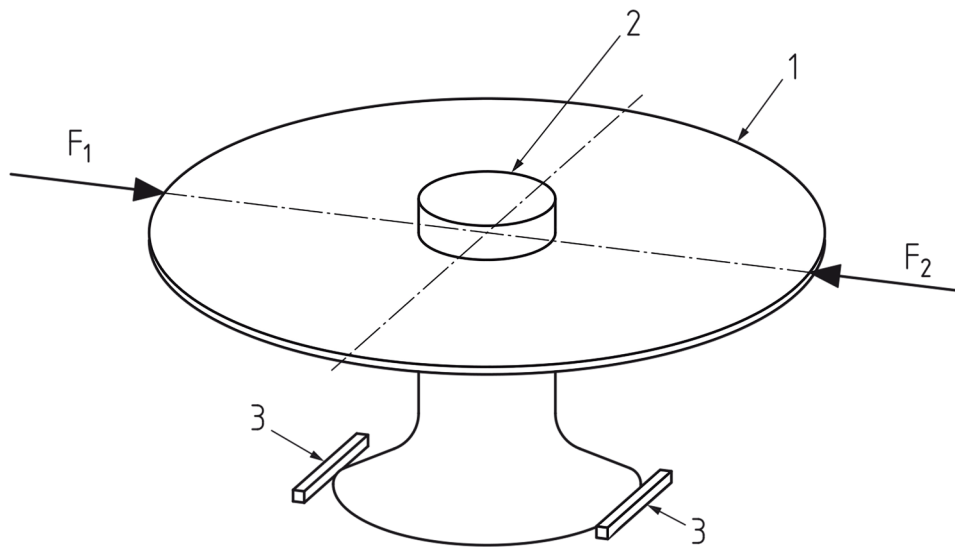

i) Oval/round table with central column – first and second directions

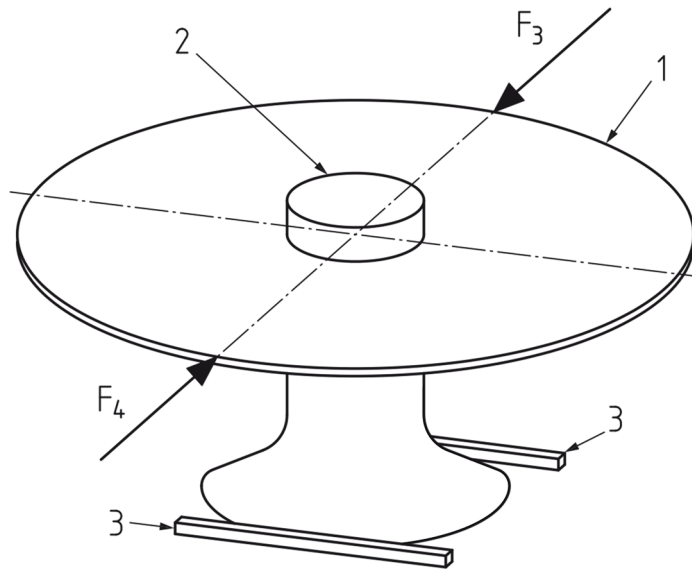

j) Oval/round table with central column – third and fourth directions

Key

- | | |
|---------------------------------|------------------|
| F_1 force in first direction | 1 table |
| F_2 force in second direction | 2 specified mass |
| F_3 force in third direction | 3 stop |
| F_4 force in fourth direction | |

Figure 2 — Examples of positions of forces and stops in horizontal static load test

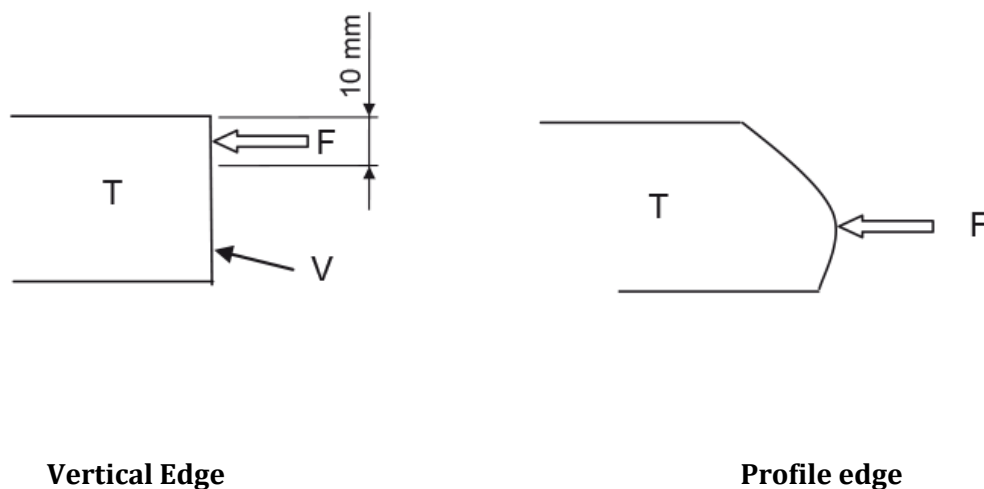

Figure 3 — Vertical edge v. profile edge

Key

F	Horizontal force
T	Table top
V	Vertical edge

6.3 Vertical static load tests

6.3.1 Vertical static load on main surface

Height adjustable tables shall be set to their highest position but not to exceed 950 mm.

Apply the specified vertical downward force using the loading pad (5.4) anywhere on the top that is most likely to cause a failure, but not less than 100 mm from any edge. If the table tends to overturn, gradually move the loading point towards the centre of the table until this tendency ceases.

If there are several such positions, carry out the test at a maximum of three different positions.

Repeat the procedure for each point a total of 10 times.

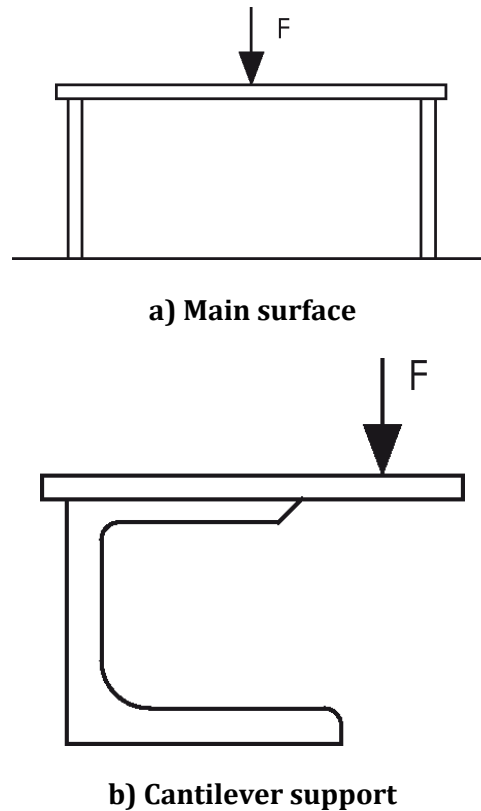

Key

F vertical static load

Figure 4 — Vertical static load test - main surface

6.3.2 Additional vertical static load test where the main surface has a length > 1600 mm

Measure the table's greatest length. If it is greater than 1600 mm conduct this test.

Height adjustable tables shall be set to their highest position but not to exceed 950 mm.

Apply two vertical downward forces simultaneously using the loading pad (5.4) at points positioned on the longitudinal axis of the table top, 400 mm on either side of the transversal axis. See Figure 5.

The longitudinal axis of a non-symmetrical table shall be a line drawn between the two points furthest apart.

Apply and remove the load a total of 10 times.

Dimensions are in millimetres

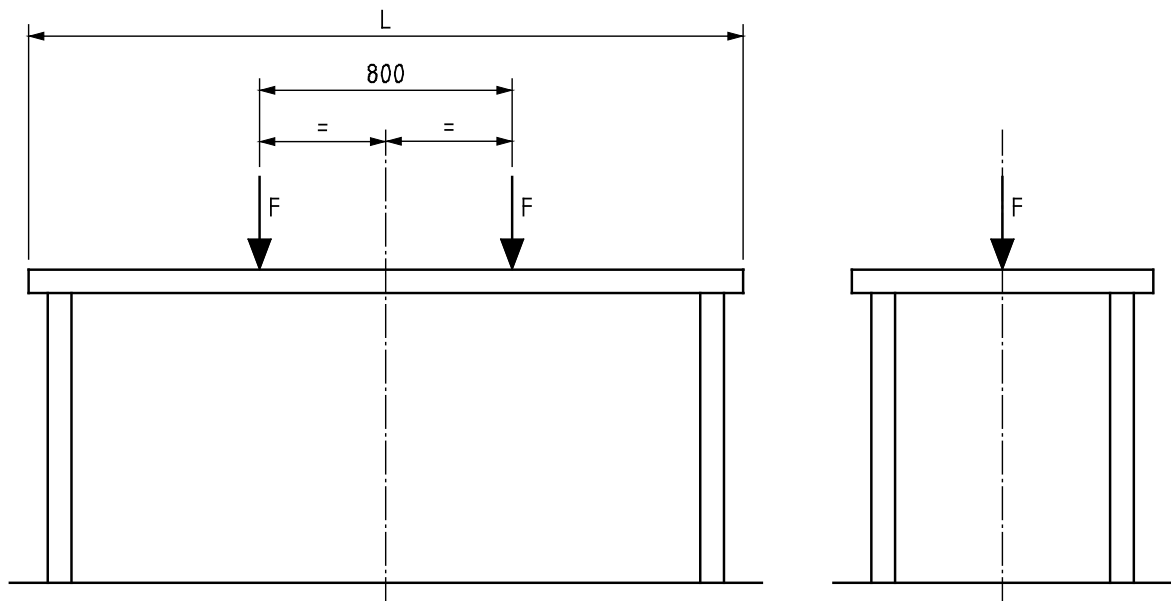
**Key**

- L length of top
F vertical static load

Figure 5 — Additional vertical static load test**6.3.3 Vertical static load on end extension**

A table extension inserted within the main frame of the table shall be considered as the main surface. A part of the main surface in the unextended configuration may become an end extension in the extended configuration.

Height adjustable tables shall be set to their highest position but not to exceed 950 mm.

Apply a vertical downward force using the loading pad (5.4) anywhere on the end extension that is likely to cause a failure, but not less than 100 mm from any edge (see Figure 6). If there are several such positions repeat the test at a maximum of two different positions.

If the table tends to overturn, gradually move the loading point towards the main surface (the force must remain on the end extension) until this tendency ceases.

The test shall be run for 10 cycles.

NOTE If deflection measurements are required from a specifier, maintain the load at the last cycle for 30 minutes in order to measure the maximum deflection, Δ . The maximum deflection, Δ , is the difference in height at the point of loading, between the initial unloaded state and the final state under load. There are no recommended requirements for deflection for this test in Annex A.

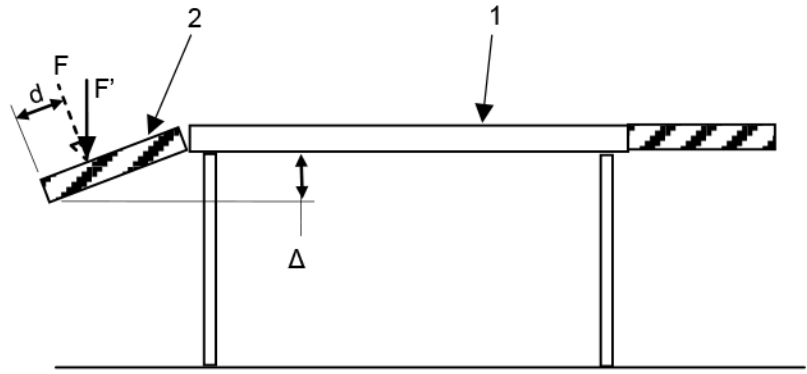

Key

- | | | | | | |
|---|----------------------|---|---------------|---|------------|
| d | 100 mm minimum | 1 | main surface | Δ | deflection |
| F | vertical static load | 2 | end extension | | |

Figure 6 — Vertical static load test – end extension

6.4 Horizontal durability and stiffness test

6.4.1 General

Position the table on the test surface, in its normal position of use. Tables with extensions inserted in the centre shall be tested in the extended configuration. All other tables shall be tested without end extensions. This test does not apply to tables with castors unless there are at least two castors with locking devices.

Height adjustable tables shall be set to their highest position but not greater than 950 mm.

Restrain the base of the table by placing stops around each leg/base (in all directions) (see Figure 7).

For type 1 units, place a 50 kg mass on the table top on an area of (300 ± 50) mm x (300 ± 50) mm, or a diameter of (300 ± 50) mm, at the point most likely to prevent the table lifting off the floor. For type 2 units, the mass shall be 25 kg.

6.4.2 Horizontal durability test

Apply two alternating 300 N horizontal forces within 10 mm of the table top surface by means of two loading pads (5.4), one at one end of the table 50 mm from one corner/edge, a, (and one at the opposite end/edge, b, (see Figure 7 a)).

If the table top is not secured to the understructure and the top moves when the specified force is applied, reduce the force sufficiently to prevent movement. Perform the test using this reduced force in that direction only. Record the value of any reduced force used.

If the table tends to lift in one direction of loading at a load less than that specified, reduce the horizontal force sufficiently to prevent lifting. Perform the test using this reduced force in that direction only. Record the value of any reduced force used.

Repeat the procedure at the other corner positions, c and d, (see Figure 7 a).

Carry out the test for the number of cycles specified.

The test may be carried out in a one stage cycle a, c, b, d or in a two-stage cycle a, b followed by c, d.

For table tops with a cantilever support at one end, carry out the test as shown in Figure 7 b).

For table tops attached to another table top at one end, carry out an additional test as shown in Figure 7 c).

If measurements of the horizontal movement are required, this shall be measured at the beginning and end of the test, when the load is changed from one end to the opposite end.

For tables with circular or oval tops, direction a, b shall be through the longitudinal axis. Direction c, d shall be on a line perpendicular to the direction a, b and 50 mm from outermost edge of the table (see Figure 7 d)).

For tables with curved table tops special loading pads may be used.

For tables with a triangular base or three legs, direction a, b shall be perpendicular to one side of the base or to the line joining two legs and passing throughout the third corner of the base or the third leg. Direction c, d shall be parallel to one side of the base or the line joining two legs. For tables with circular or oval tops, and featuring a triangular base or three legs, a, b shall be through the longitudinal axis. Direction c, d shall be on a line perpendicular to the direction a, b and 50 mm from outermost edge of the table (see Figure 7 e)).

For tables with circular or oval tops, and featuring a cross leg support, direction a, b shall be through the longitudinal axis. Direction c, d shall be on a line perpendicular to the direction a, b and 50 mm from outermost edge of the table (see Figure 7 f)).

All dimensions in millimetres

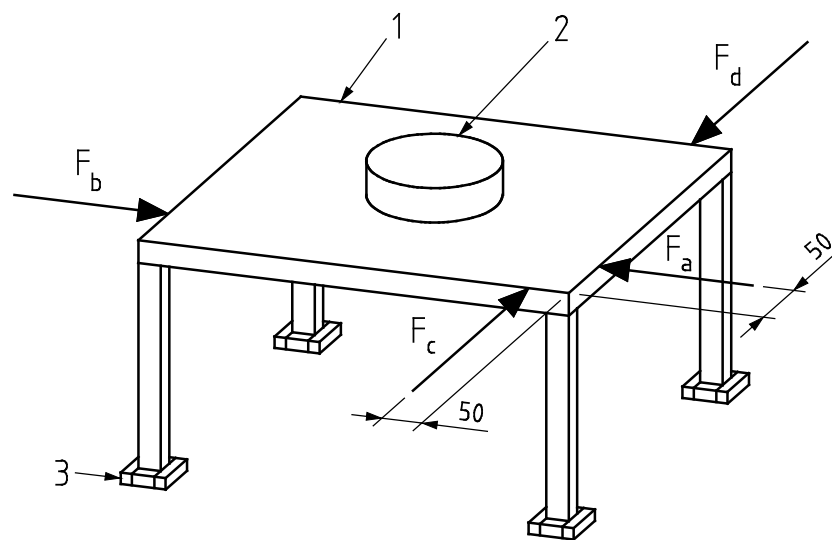

a) Main surface

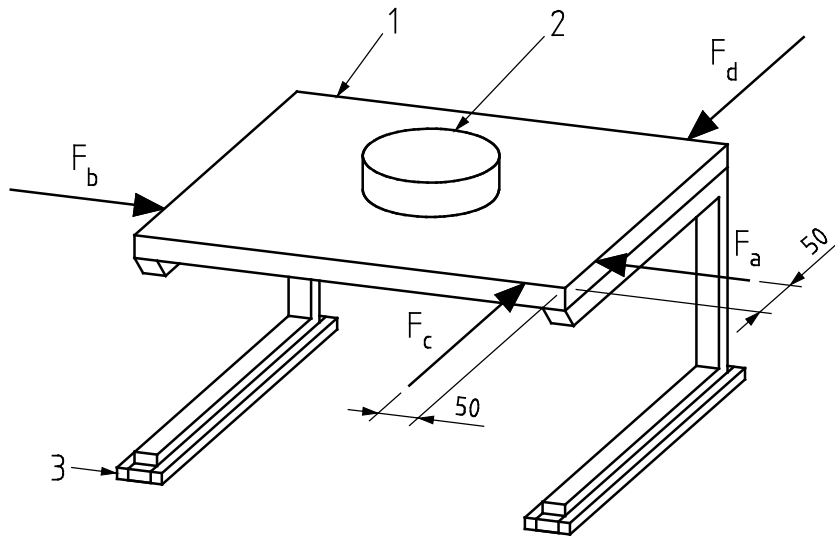

b) Cantilevered tables

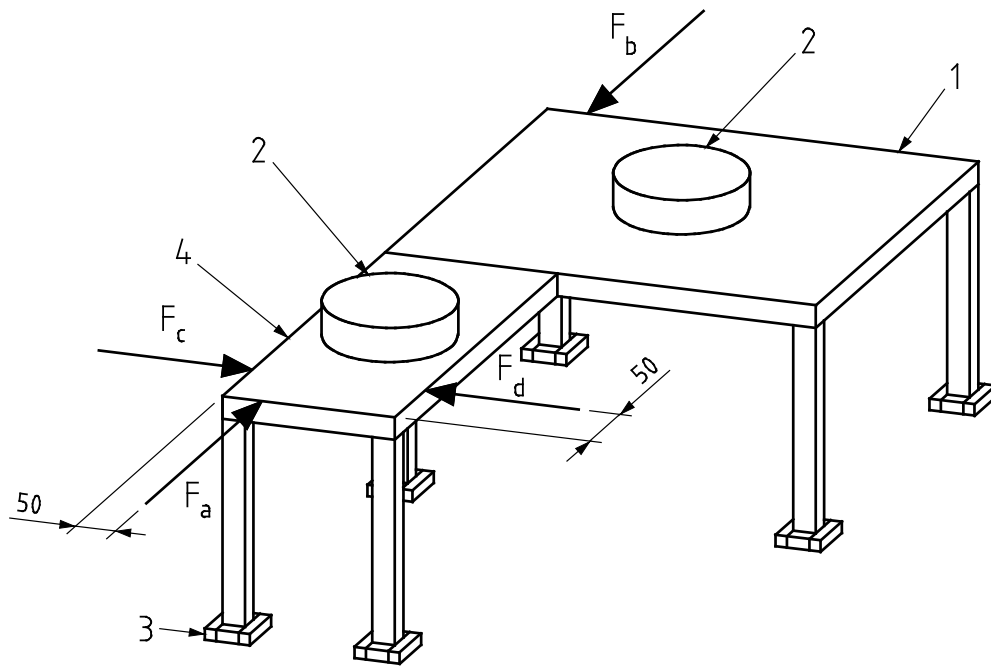

c) Additional tops

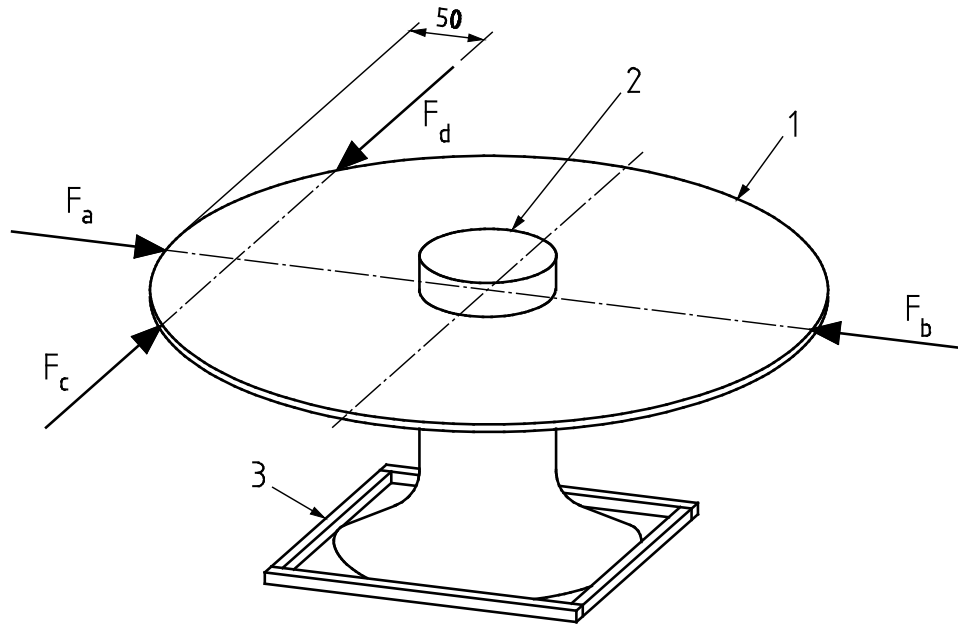

d) Round and elliptical tops

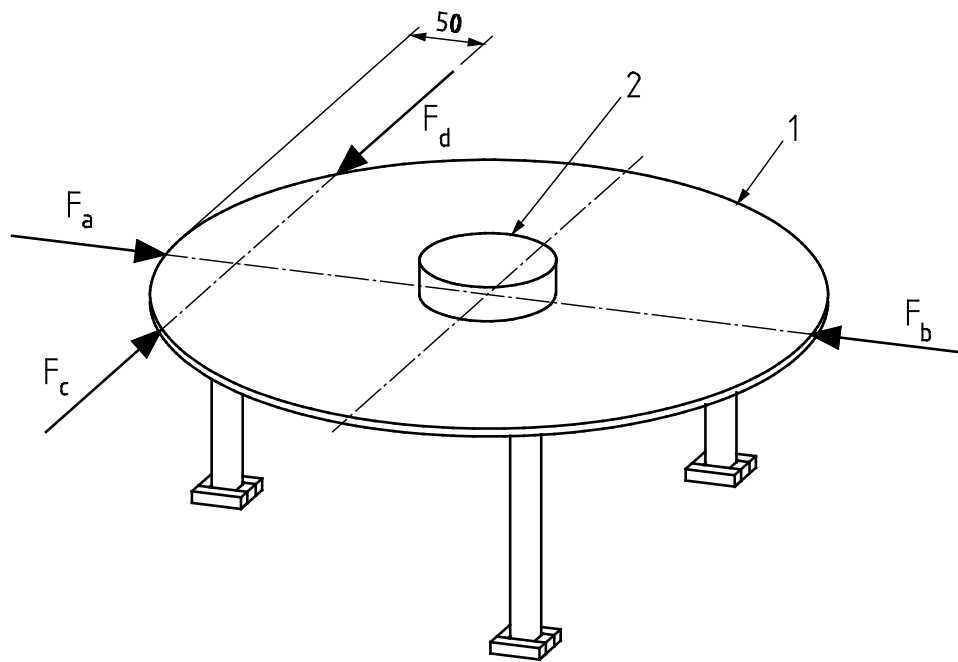

e) Round and elliptical tops with three legs

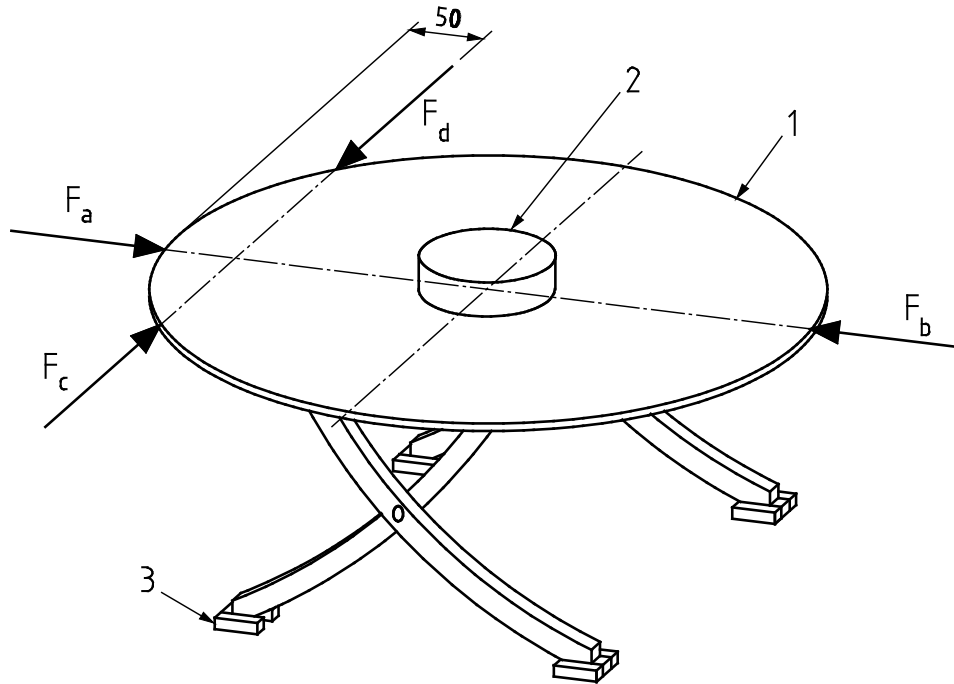

f) Round and elliptical tops with crossing legs

Key

- | | |
|---|------------------|
| F _a force applied at point a | 1 main table top |
| F _b force applied at point b | 2 specified mass |
| F _c force applied at point c | 3 stops |
| F _d force applied at point d | 4 additional top |

Figure 7 — Horizontal durability test

6.4.3 Stiffness of the structure

This test is applicable to tables 950 mm or less in height. Height adjustable tables shall be set to their highest position but not to exceed 950 mm.

A table extension added in the centre of the table shall be considered as the main surface.

For type 1 units, place 50 kg on the table top on an area of (300 ± 50) mm x (300 ± 50) mm, or a diameter of (300 ± 50) mm, at the point most likely to prevent the table lifting off the floor. For type 2 units, the mass shall be 25 kg.

Apply a force of 200 N by means of the loading pad (5.4). For vertical flat edge tops, apply the horizontal force by means of the loading pad centred within 10 mm of the table top surface in a direction perpendicular to a line joining the two legs/supports, midway between the legs/supports. For tops without a vertical edge (profile-edge), apply the load with the loading pad centred at the outermost edge. (see figure 3).

Maintain the force for (10 ± 1) s and record the position of a point D on the length of the table. Remove the force and repeat it in the opposite direction and record the distance of the horizontal travel of the point. The total distance point D moves, from its location when the force in one direction is applied to its location when the force is applied in the other direction, is D₁. (See Figure 8 a)) Calculate and record D₁.

Repeat the procedure using horizontal forces along the transverse centreline. The total distance point D moves, from its location when the force in one direction is applied to its location when the force is applied in the other direction, is D_2 . (See Figure 8 b)) Calculate and record D_2 .

If the table top is not secured to the understructure and the top moves when the 200 N force is applied, reduce the force sufficiently to prevent movement. Perform the test using this reduced force in that direction only. Record the value of any reduced force used. The applied force shall not be reduced below 100N.

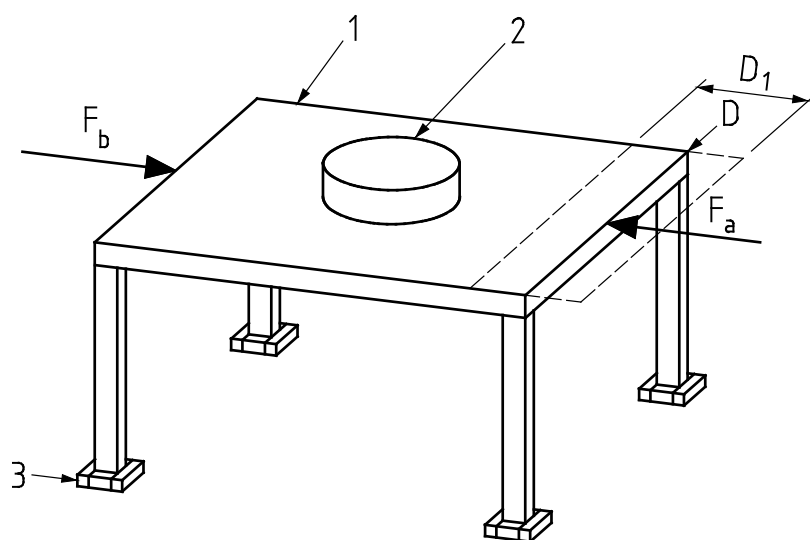

a) Longitudinal direction

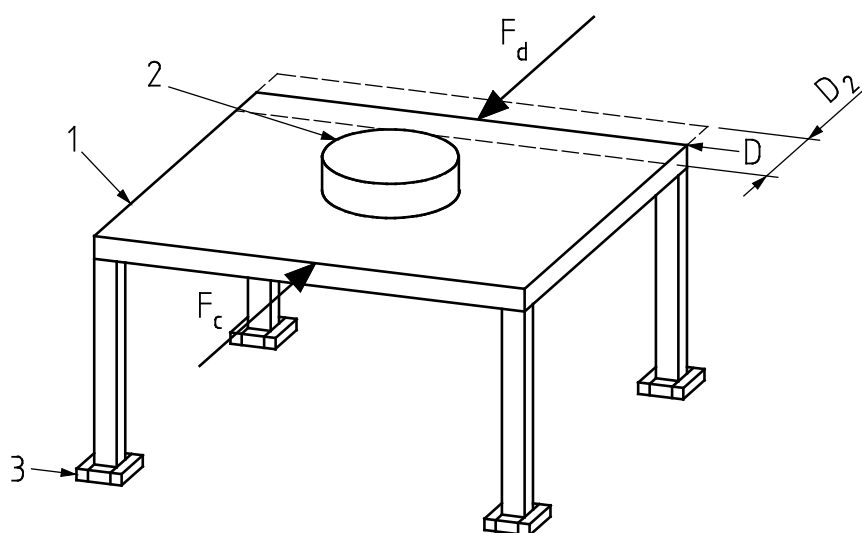

b) Transverse direction

Key

- | | |
|-------------------------------------|------------------|
| F_a force applied at point a | 1 main table top |
| F_b force applied at point b | 2 specified mass |
| F_c force applied at point c | 3 stops |
| F_d force applied at point d | |
| D measurement point | |
| D_1 distance travelled by point D | |
| D_2 distance travelled by point D | |

Figure 8 — Stiffness of the structure

6.5 Vertical durability test

Position the table on the test surface in its normal position of use. Tables with extensions inserted in the centre shall be tested in the extended configuration. All other tables shall be tested without extending end extensions.

Height adjustable tables shall be set to their highest position but not to exceed 950 mm.

Apply the vertical force 300 N by means of the loading pad (5.4), on the table top at the most adverse position, 100 mm from the table top edge.

If the article tends to lift, load the centre of the main table top with a mass sufficient to prevent overturning.

Carry out the test for the specified cycles.

6.6 Vertical impact test

6.6.1 General

Position the unit on the test surface and level in its normal position of use. Tables with extensions inserted in the centre shall be tested in the extended configuration. All other tables shall be tested without extending end extensions. Height adjustable tables shall be set to their highest position but not to exceed 950 mm.

6.6.2 Vertical impact test for glass table tops

Place the unit on the floor surface.

The impact point on glass surface shall be in the horizontal plane. If necessary, the unit shall be tilted.

Place a piece of foam (5.9) on the glass surface to be impacted in the worst-case location.

With the impactor (5.1) resting on the foam, adjust the fall height to 50mm above the resting position. Let the impactor fall freely onto the foam.

Before each impact, check that there are no glass splinters in the polyurethane foam or in the striking surface of the impactor.

Repeat impact testing a total of 10 times.

6.6.3 Vertical impact test for all other table tops

Place one layer of foam (5.5) on the table top.

The height of drop shall be measured from the position where the impactor is resting on the surface of that layer of foam. Place a second layer of foam (5.5) between the striking surface and the table top.

Allow the vertical impactor (5.1) to fall freely from a height of 100mm above the resting position identified above, onto the foam surface at the following three locations:

- as close as possible to one point of support of the top but not less than 100 mm from any edge;
- 100 mm from the edge of the top as far away from the supports (structure) as possible;

— 100 mm from the edges at one corner.

Allow the impactor to fall freely through the specified drop height onto the foam on the foam-covered table top for 10 cycles at each position.

6.7 Deflection of table tops

Position the table on the test surface, in its normal position of use. Tables with extensions inserted in the centre shall be tested in the extended configuration. All other tables shall be tested without extending end extensions.

Testing of the deflection of table tops that are not made of metal, glass or stone, shall be carried out in a relative humidity as specified in 4.1.

The greatest deflection shall be measured and recorded with reference to a straight line to an accuracy of $\pm 0,1$ mm.

Place the table being tested on the floor surface (5.2). Load the table top with a uniformly distributed load of 1.5 kg/dm^2 for:

- one hour for table tops made of metal, glass and stone;
- one week for all other table tops.

With the load remaining on the top, measure and record the deflection at a point 50 mm from an edge where the deflection is greatest, with reference to a straight edge placed along and extending the entire length or diameter of the table top. The deflection is the difference in height between the straight edge and the final state under load.

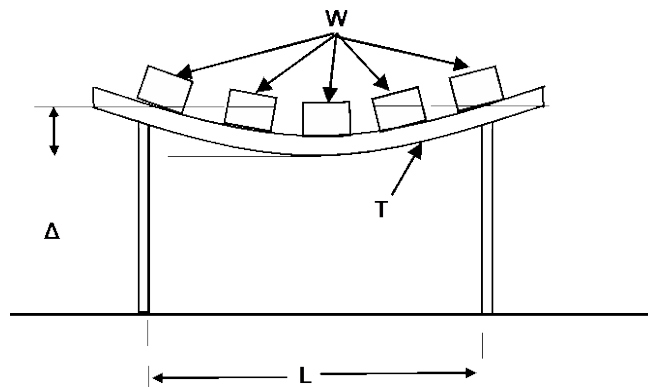

Key

- | | | | |
|---|-------------------------|---|---------------------------|
| L | Length between supports | W | Evenly distributed weight |
| T | Table top | Δ | Deflection of table top |

Figure 9 — Deflection of table tops

6.8 Durability of tables with castors

Tables shall be tested without extending surfaces. Adjustable height tables shall be positioned at the midpoint of the adjustable range.

Place the table on the floor surface (5.2) with specified height obstacle.

Apply a load of 50 kg centred on the table top. For Type 2 tables the load shall be 25 kg.

The castors shall be free to rotate and swivel.

Position the table such that it shall move through its travel along its longitudinal axis of the table. Guides may be used to keep the table aligned on the test surface.

The operating force shall be applied no lower than 50 mm from the top surface of the table, but not higher than 950 mm. The method of attachment shall not support the unit during the test. For tables with castor and levelling device (3.4) combinations, the legs without castors may be raised a maximum of 50 mm above the test platform/surface during this test.

Adjust the length of travel to (1000 ± 50) mm. Position the obstacles to ensure that all castors travel over an obstacle twice for each cycle. The table travel shall be adjusted so that after changing direction at each end of travel, provide 200 mm to 400 mm of travel before encountering an obstacle. Only two castors will pass over an obstacle at one time. One cycle consists of one movement forwards and backwards. The test shall operate at a rate of (6 ± 2) cycles per minute.

Upon completion of the test, inspect the castors and the structure for damage affecting the function.

6.9 Drop test

Place the table unloaded on the floor surface (5.2), in its normal position of use, without any surfaces inserted or end extensions extended. Height adjustable tables shall be set to their lowest position. Note: Any stored extension elements shall remain stored in the table.

Determine and record the most likely lifting point(s).

Determine the drop height as a percentage of the specified nominal drop height in accordance with Table 1.

The vertical force is determined as the lowest upwards vertical force to lift at least one leg/support off the floor (10 ± 5) mm off the floor.

For tables that have a single leg/support the vertical force is determined as the lowest upwards vertical force to lift the edge of the support (10 ± 5) mm off the floor.

Table 1 — Determination of drop height

Vertical force [F_V] (N)	% of specified nominal drop height
$0 < F_V \leq 200$	100
$200 < F_V \leq 220$	93
$220 < F_V \leq 240$	86
$240 < F_V \leq 260$	79
$260 < F_V \leq 280$	72
$280 < F_V \leq 300$	65
$300 < F_V \leq 320$	58

Vertical force [F_v] (N)	% of specified nominal drop height
$320 < F_v \leq 340$	51
$340 < F_v \leq 360$	44
$360 < F_v \leq 500$	37
$F_v > 500$	30

Lift the table at the point used to determine the vertical force to the drop height and let it drop freely onto the floor surface (5.2).

Carry out the test six times. Height adjustable tables shall be tested three times at the lowest position and three times at the highest position. Note: Standard tolerance of ± 1 mm of the nominal dimension does not apply for this test. The drop height position may be ± 2 mm of the nominal dimension.

6.10 Table Top-to-Leg Assembly Strength

Place an unloaded unit on its top on the test surface and secure it in place. The method of securing shall not add structure to the leg being tested. If the unit has glides, they shall be set at the midpoint of their adjustment range but not greater than 13 mm. Adjustable height tables shall be set at the midpoint of their adjustment range.

For Type 1 tables:

Calculate the Force “F1” as follows: “F1” = $0.5 \times (\text{unit weight, kg}) \times 10 + 222$ N (not to exceed 445 N)

Calculate Force “F2” as follows: “F2” = $0.5 \times \text{“F1”}$

For Type 2 tables:

Calculate the Force “F1” as follows: “F1” = $0.5 \times (\text{unit weight, kg}) \times 10 + 44$ N

Calculate Force “F2” as follows: “F2” = $0.5 \times \text{“F1”}$

Attach a loading device to the support member to be loaded. The placement of the loading device shall be within 25 mm of the end of the support member/glide assembly that makes contact with the floor. The placement of the loading device shall be as close to the glide end as possible (may be on the glide stem, but not on the glide foot itself). For tables with castors, apply the load as close as possible to the end of the support member but not to the castor assembly (See Figure 10).

Individually and separately apply the horizontal forces “F1” and “F2” to each unique type of table leg.

NOTE The higher “F1” forces are to be those that can be applied to a table from “outside” the unit toward “inside” the unit. The lower “F2” forces are those that can be applied to a table from “inside” the unit toward “outside” the unit. (See Figure 10).

The forces shall be applied for one cycle.

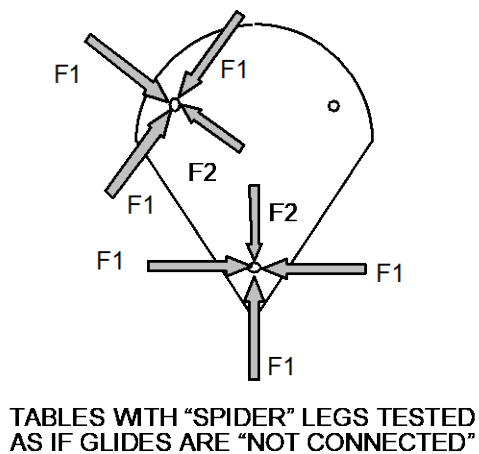
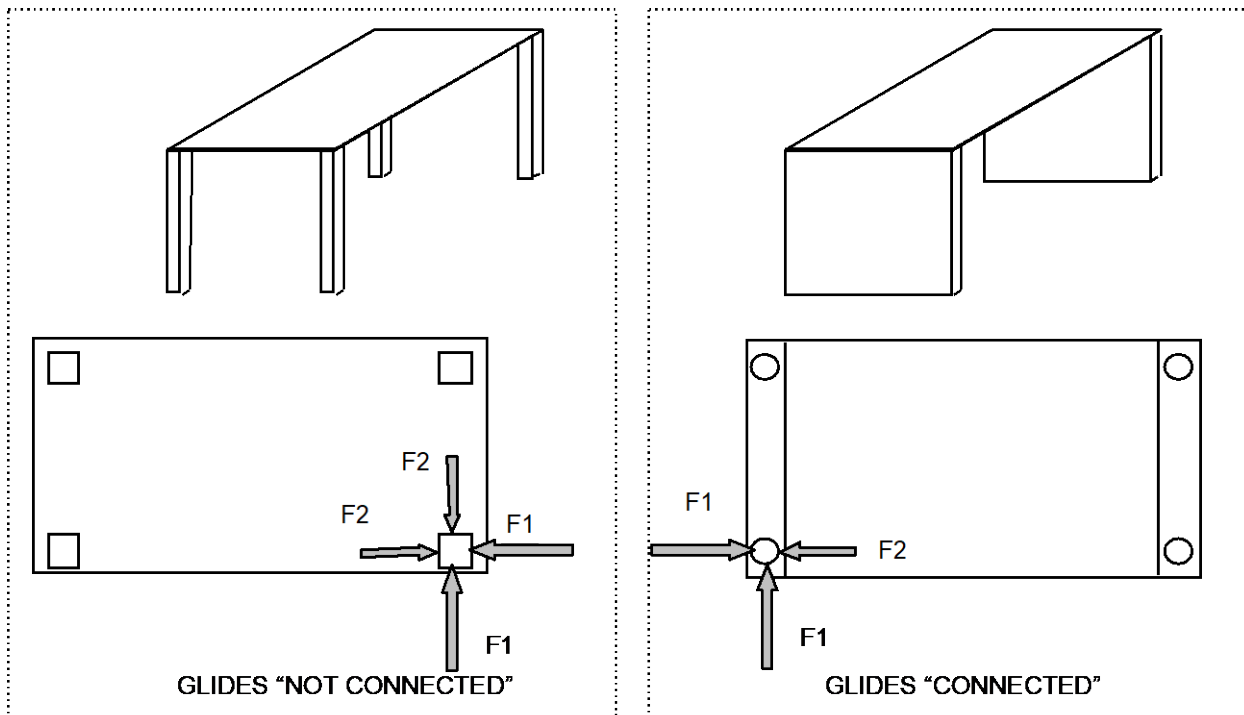

TABLES WITH "SPIDER" LEGS TESTED AS IF GLIDES ARE "NOT CONNECTED"

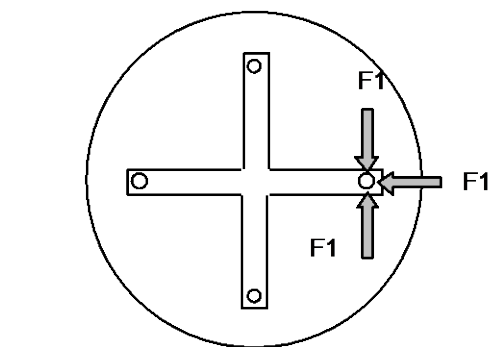

CROSS SLAB LEGS TESTED AS SHOWN ABOVE

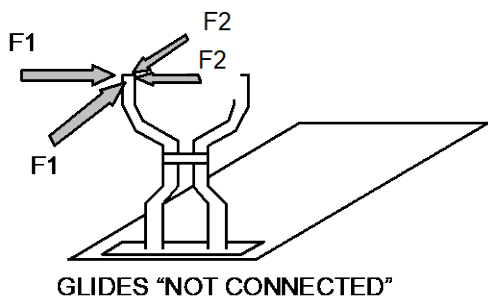

GLIDES "NOT CONNECTED"

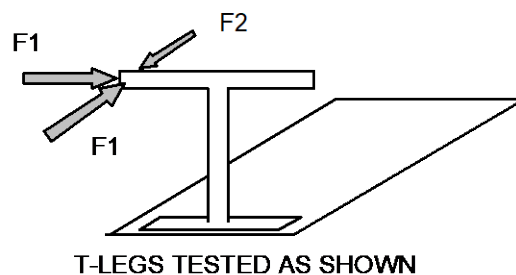

T-LEGS TESTED AS SHOWN

Figure 10a - Table Leg Strength Examples

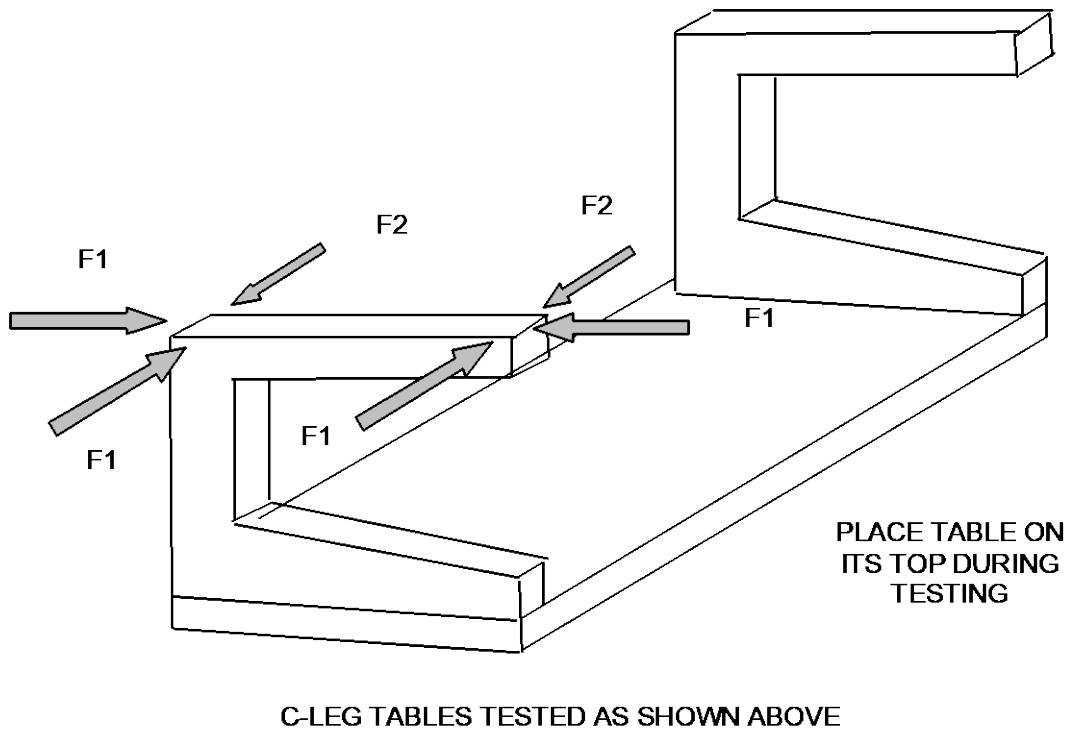

NOTE:
IT IS NOT NECESSARY TO
REPEAT TESTS ON LEGS
OR SUPPORT MEMBERS
OF IDENTICAL
CONSTRUCTION.

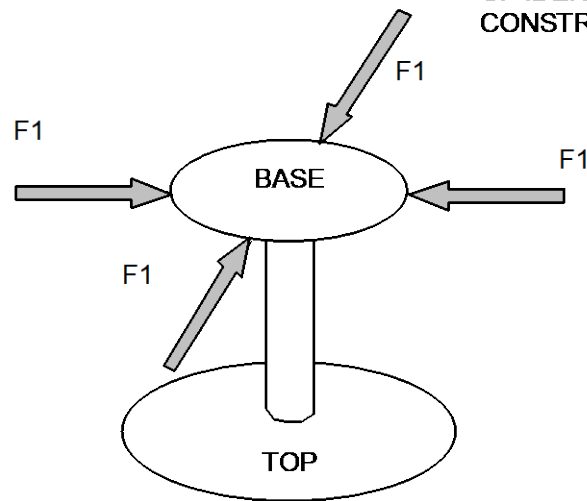

COLUMN TABLES TESTED AS SHOWN ABOVE

Figure 10b - Table Leg Strength Examples - continued

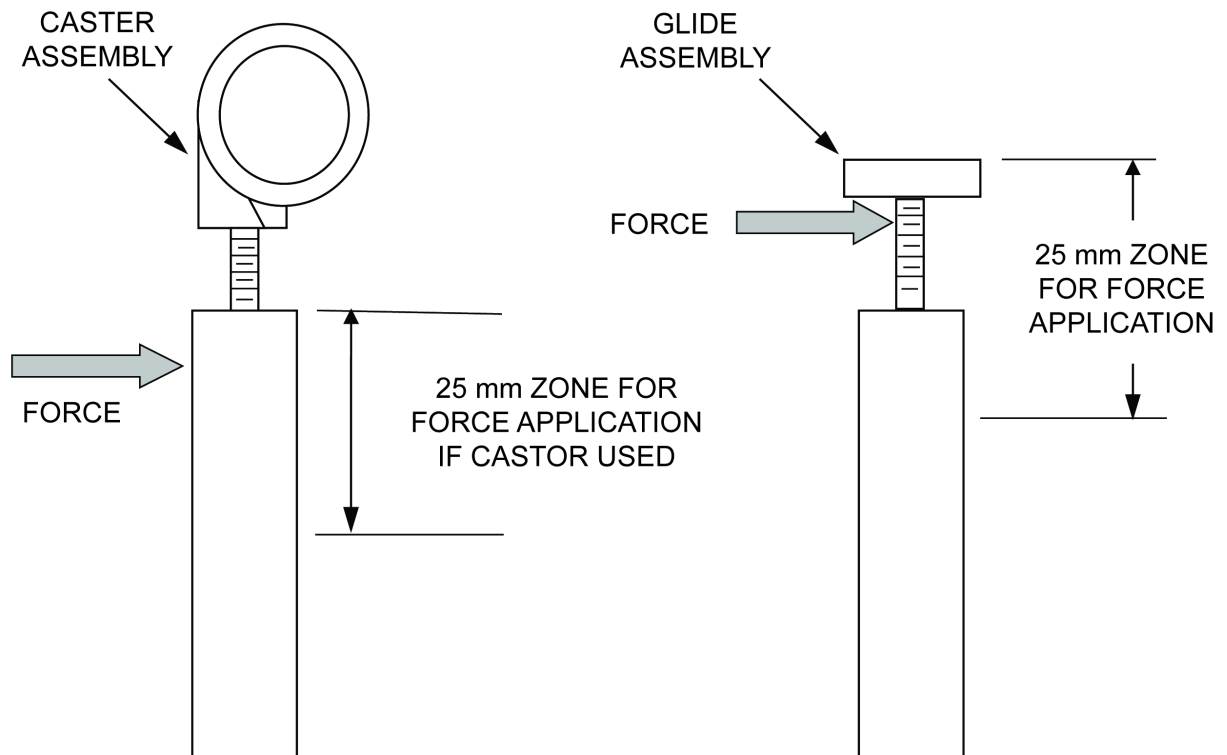

Figure 10c – Table Leg Strength Examples

7 Test procedures – Stability

7.1 General

The tests shall be carried out in the configuration most likely to cause overturning. Note: If manufacturers offer options such as screens, monitor arms, storage features, and so on; these must be considered for worst case conditions for stability.

Where the table top can be extended, and the smallest dimension of the unextended table top is less than 300 mm, then the extended configuration shall be considered most likely to cause failure. In this case, the extended configuration is considered as the main surface.

If a test cannot be carried out as specified in this standard, e.g. because a loading pad cannot be used for the application of a force due to the design of a product, the test shall be carried out as far as possible as specified.

With the exception of 7.3, tables supplied with storage features shall be tested with no load in the storage item.

7.2 Stability under vertical load

7.2.1 General

Tables that can be set to heights both above and below 950 mm shall be tested to both 7.2.2 and 7.2.3. Any unit with doors shall have the doors opened 90 degrees during the tests.

7.2.2 Test for tables that are or can be set to a height of 950 mm or less

The table shall be set to the height most likely to overturn the table, but not more than 950 mm.

The vertical load of 40 kg shall be applied 50 mm from the outer edge of the table top (see Figure 11 for one example) on that side where the load is most likely to cause overturning as far away from the supports as possible.

Where there are multiple positions that may cause overturning the test shall be repeated at each position.

The table shall not overturn.

All dimensions in millimetres

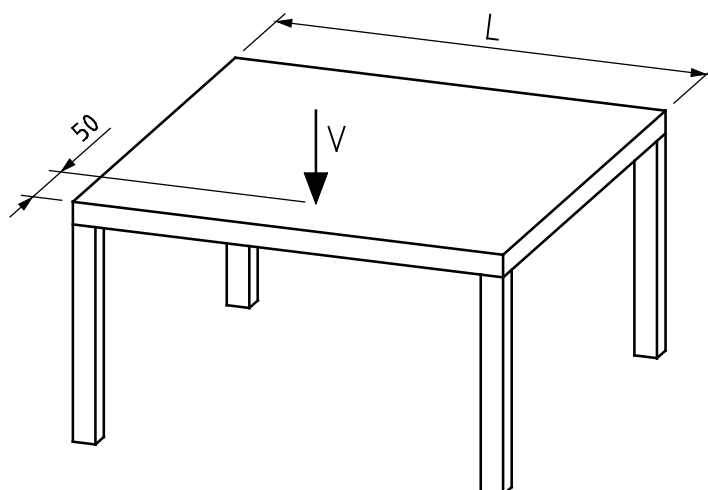

Key

- L longest dimension of table top
- V vertical load

Figure 11 — Vertical stability test

7.2.3 Test for tables that are or can be set to a height greater than 950 mm

The table shall be set to the height most likely to cause overturning, but not less than 950 mm.

The table shall not overturn when tested according to 7.2.2 using a 20 kg load.

Where there are multiple positions that may cause overturning the test should be repeated at each position.

7.3 Stability for tables with extension elements (drawers)

Load each extension element (drawer) with the load(s) specified in ISO 7170:2021 for stability tests.

For tables with extension elements not fitted with interlocks, place all extension elements in the least favourable combination. Pull out fully for units with stops. For extension elements without stops, open the extension element to 2/3 of travel. For tables with extension elements fitted with interlocks, open the two extension elements with the largest loads without overriding the interlock. If an interlock device prevents any two of the extension elements from being opened simultaneously, open the extension element with the largest load.

The table shall not overturn when a 200 N vertical force is applied at the most adverse position of the table top, through a loading pad (5.4), 50 mm from the edge.

7.4 Stability of tables designed to support a parasol

Set the table on the test surface. If adjustable in height, the table shall be set to the height most likely to cause overturning, but not more than 950 mm.

Secure the test tube (5.6) in the table's fixture for holding parasols.

Apply the specified horizontal force 30 N at a height h of 2 200 mm. Figure 12 shows an example of a table where the structure is intended to support a parasol.

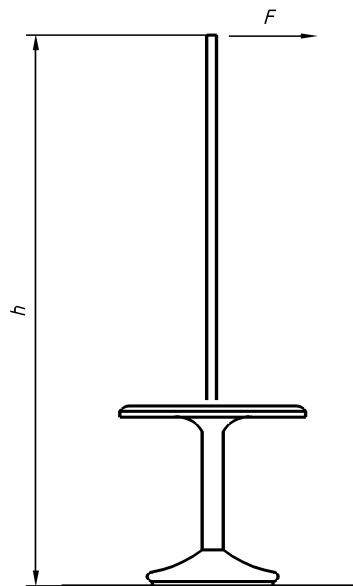

Key

F horizontal force

h height

Figure 12 — Stability of tables where the structure is intended to support a parasol

7.5 Horizontal Stability Test for Tables with Castors

The unit shall be placed on a level platform and leveled. Adjustable height desk/tables shall be positioned at a height that places the desk/table in its least stable condition. Locate screens and modesty panels in the least stable position.

Apply a 12 kg static load through a 200 mm diameter disk centered 100 mm from the edge of the top of the desk/table at the least stable location.

If applicable, castors that support the load shall be blocked with an obstruction or other restraining device 13 mm in height affixed to the test platform. The device shall prevent sliding but not restrict the unit from tipping. Castors shall be oriented in their least stable position.

Gradually apply a horizontal force to the top surface, perpendicular to the worst-case fulcrum (“tipping line”) but not more than 13 mm below the top surface directly opposite the load. If the geometry of the top surface does not permit a direct application of the load, the geometry of the top surface may be altered to accommodate the 13 mm dimension. (See Fig. 13). The load shall be applied perpendicular to the line formed by the castor obstruction(s) until 44.5 N (is reached, or the product tilts to 10 degrees minimum, whichever occurs first. The force applied shall remain horizontal throughout its application. A test fixture/adaptor shall be used if the edge of the top is not parallel to the line formed by the obstruction(s). (Fig. 13)

If necessary, repeat the above steps to verify the least stable position has been evaluated. The table shall not overturn.

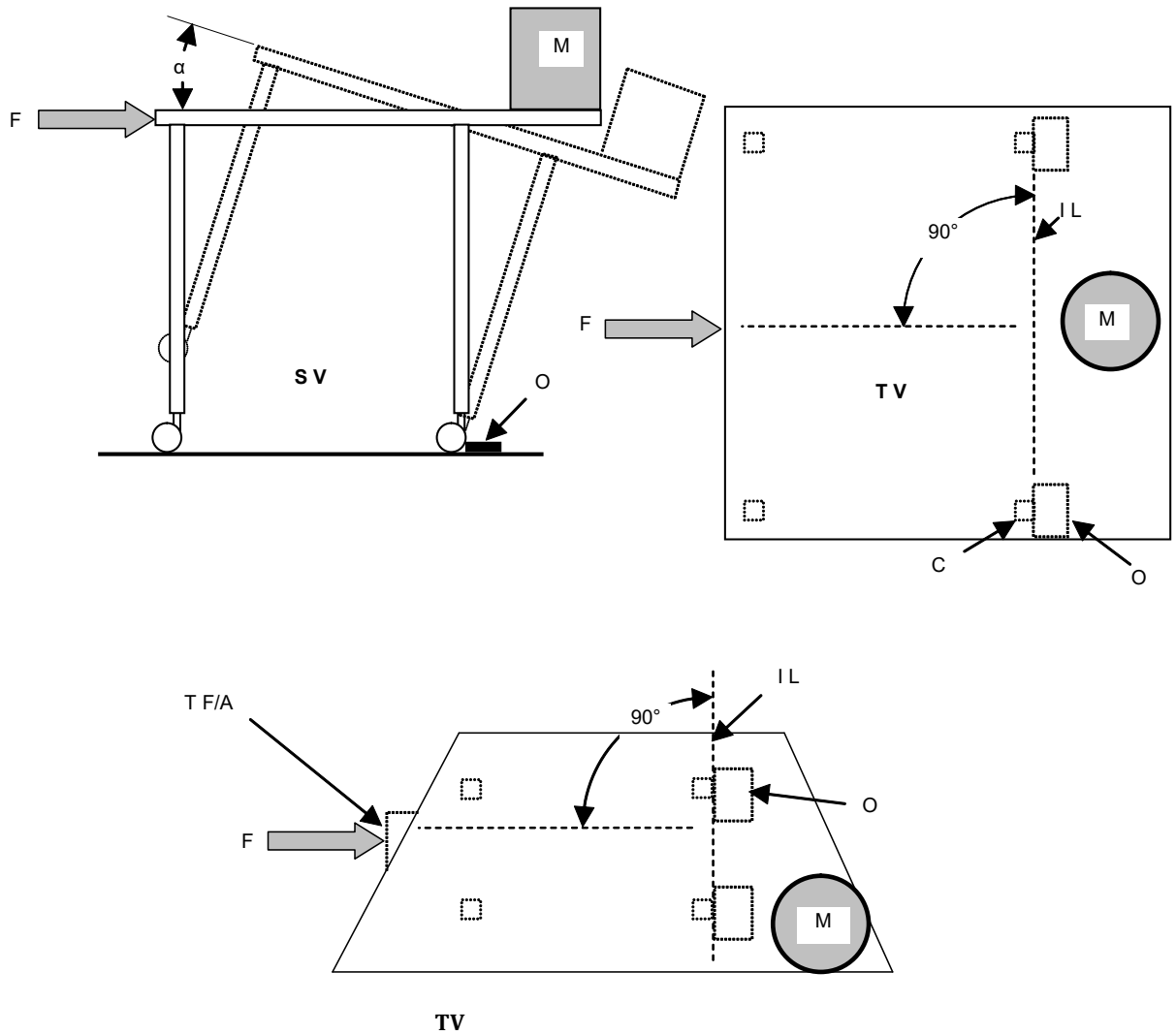

Key

- C castor (if applicable)
- F force - applied not more than 13 mm below the top edge; geometry of edge may be altered if necessary to allow application of load
- IL imaginary line
- M mass
- TF/A test fixture/adapter, if necessary, to assure perpendicular loading towards obstructions
- O obstruction (stop)
- α angle
- SV side view
- TV top view

Figure 13 — Horizontal Stability Test

7.6 Force Stability Test for Tall Products

This test applies to any unit that is higher than or can be adjusted to heights greater than 1067 mm.

NOTE See Informative Annex B for more detail regarding applicability.

The unloaded unit shall be placed on a test platform and leveled or positioned in accordance with the manufacturer's instructions. If the unit is equipped with leveling devices (3.4), extend them to their midpoint but not to exceed 13 mm from the fully retracted position. Leveling devices, feet or castors shall be blocked with an obstruction or other restraining device 13 mm in height affixed to the test platform. The device shall prevent sliding but not restrict the unit from tipping. Adjustable height desk/tables shall be positioned at a height that places the desk/table in its least stable condition. Castors shall be oriented in their least stable position. Doors and/or extendible elements in the desk/table unit shall be closed and unlocked.

Apply the horizontal forces through the center of a disk that is 200 mm in diameter. If the geometry of the product inhibits the use of the 200 mm disk, apply the force through a smaller diameter disk. If the location for the force is centered on an open area, then move the location of the force to the closest vertical or horizontal location on the unit.

Gradually increase the force until 200 N is reached, the product tilts to 10 degrees, or the horizontal movement at the point of application is 165 mm, whichever occurs first. The forces shall be applied one at a time to the following locations in the order given located 1372 mm from the floor or 100 mm down from the top edge, whichever is lower:

- location 1: Apply force to front of the product at its left side,
- location 2: Apply force to front of the product at its right side,
- location 3: Apply force to back of the product at its left side,
- location 4: Apply force to back of the product at its right side.

See Figure 14 for a description of the force locations.

The unit shall not overturn.

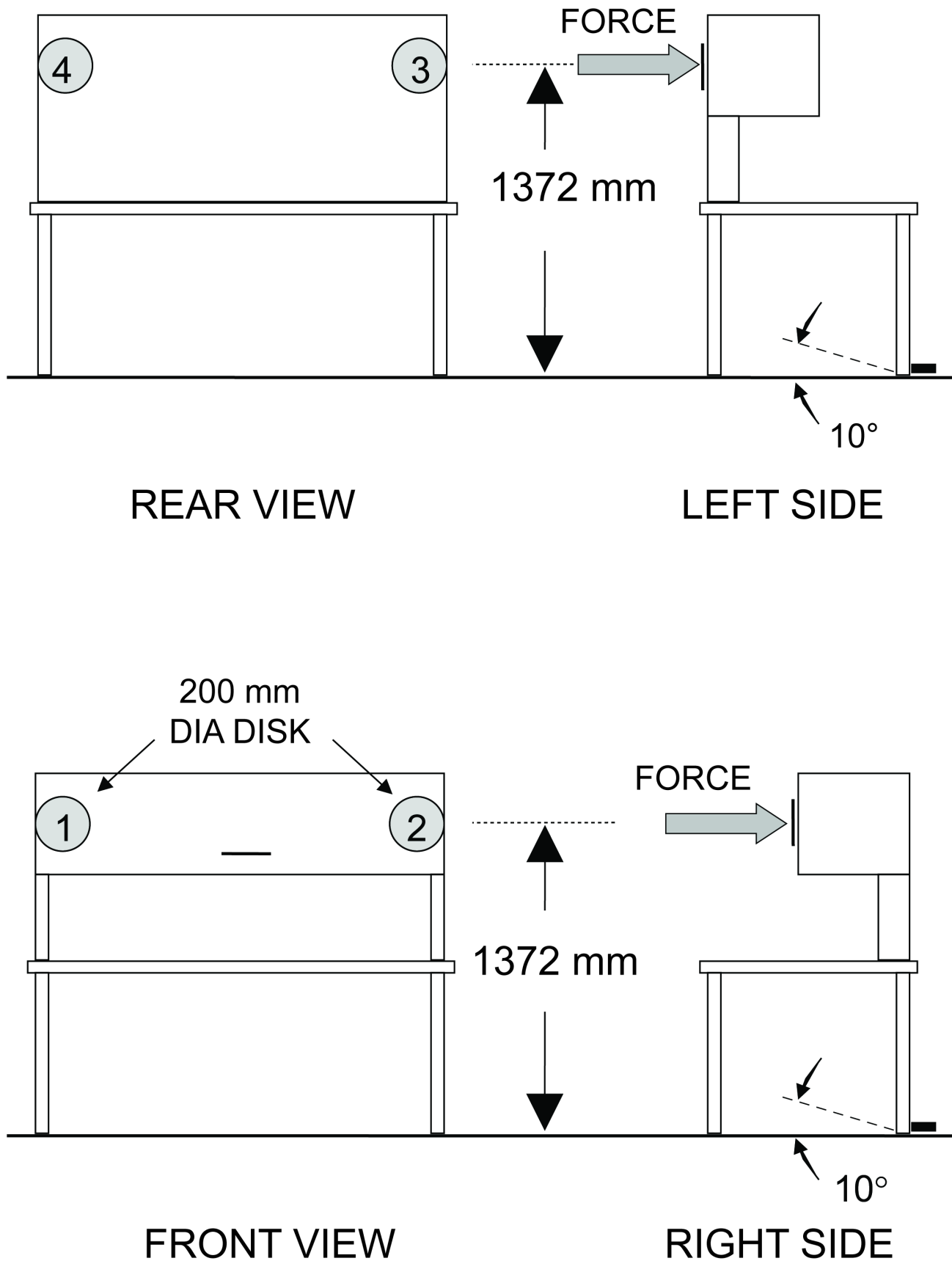

Figure 14 — Force Stability Test for Tall Products

8 Test procedures – Height adjustment mechanism

8.1 General

This test is only applicable to tables that are designed to be adjusted in height (both raising and lowering) by the user, when there is an additional load on a table, as specified in the requirements document.

If a test cannot be carried out as specified in this standard, the test shall be carried out as far as possible as specified.

Tables supplied with storage features shall be tested with the specified load in the storage item.

8.2 Durability of Height adjustment mechanism

Place the table on the floor surface (5.2).

Load the table top with the masses applied at the positions specified below.

Cycle the table, including any latches or activation mechanisms for the specified cycles as described below. The test device shall apply only those forces necessary to achieve the required motion and shall not add weight to the table. The latching and/or activating mechanisms may be cycled concurrently or independently for the complete test.

First 25 % of cycles: The table shall be cycled 90% of its total vertical travel, with a concentrated load (mass) positioned at the front left corner and another load (second mass) distributed along the back of the surface. See Position 1 in Figure 15.

Next 50 % of cycles: The table shall be cycled to cover 25% of the total vertical travel at the upper end of the range but do not contact the upper stop. A concentrated load (mass) to be positioned at the centre of the top and another load (second mass) distributed along the back of the surface. See Position 2 in Figure 15.

Last 25 % of cycles: The table shall be cycled 90% of its total vertical travel, with a concentrated load (mass) positioned at the front right corner and another load (second mass) distributed along the back of the surface. See Position 3 in Figure 15.

One cycle shall comprise of travel up and down.

The cycle rate shall not exceed six cycles per minute.

The duty cycle rate for electrically driven tables includes the amount of time the drive system may be operated and the amount of time it shall not be operated to allow the drive system to cool sufficiently before it is activated again. The duty cycle shall be as recommended by the manufacturer. When the duty cycle is not recommended by the manufacturer, the duty cycle shall be “three cycles on and then off for the equivalent time it takes to run 15 cycles.” Note: Motor-driven mechanisms that are software-controlled or have other control mechanisms to prevent damage during typical use shall not be disabled.

The duty cycle may be increased when temperature control is agreed with the manufacturer.

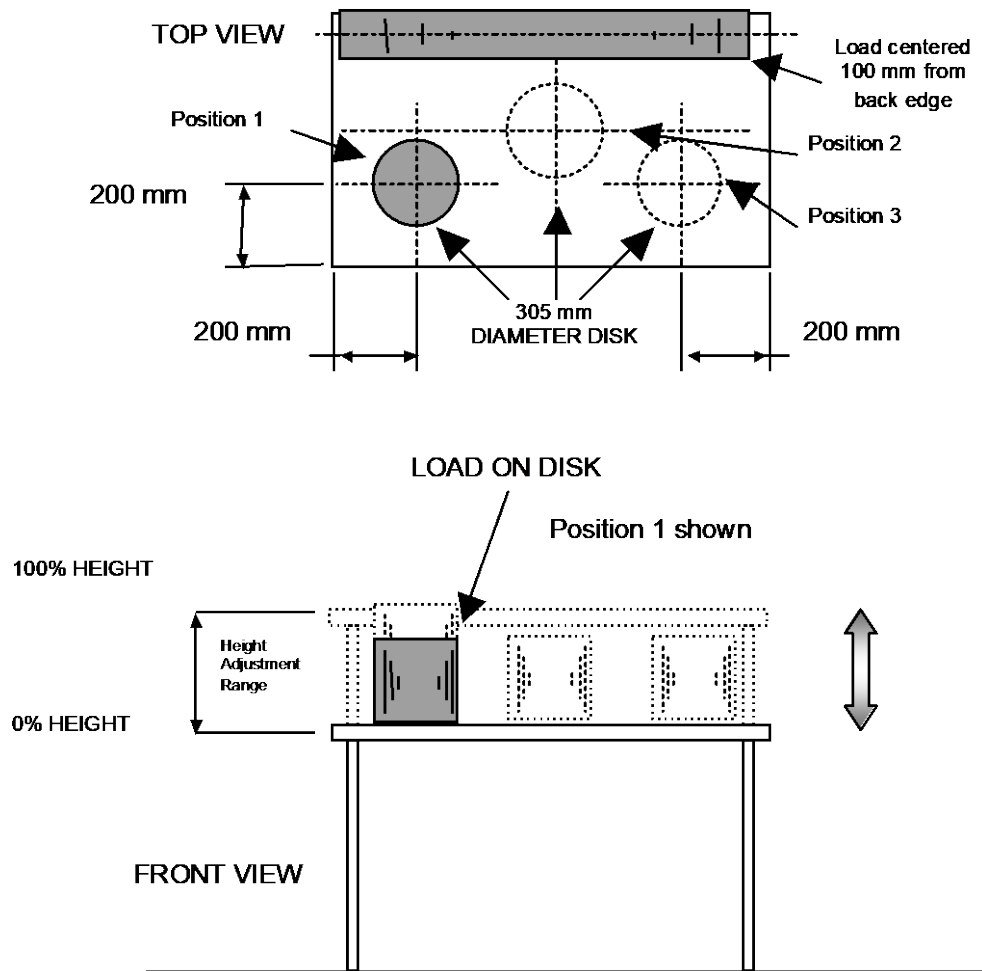

Figure 15 — Height Adjustable Mechanism Test

9 Tilting Top Table -- Cycle Test (See Figure 16)

9.1 Test Setup

- a) The desk/table unit shall be placed on a test surface/platform, leveled, and the table base shall be restrained from movement.
- b) The table top shall be cycled through its range of motion for this test.
- c) The table top shall be cycled such that any locking/latching mechanism(s) are engaged at both ends of travel, as applicable. As an option, the locks/latches and table pivot mechanisms may be cycled independently, however the test shall cycle all latch ramps and other characteristics in a manner that simulates in-use conditions and the movement of the table top shall allow it to touch the stops without impacting or overriding the stops. If tested independently, all tests must be performed on the same unit. If tested independently, the table pivot mechanism shall be tested before the lock/latch mechanism. The upper latch mechanism (if applicable) shall be tested before the lower latch mechanism.

- d) The cycle rate shall not exceed 10 cycles per minute.

9.2 Test Procedure

Move the table top from its in-use position (typically its horizontal or near horizontal position) to its fully stowed position (typically vertical or near vertical) and then return to its in-use position for the specified number of cycles.

NOTE If a cycling device is used, then center the device on the top within 50 mm of the edge.

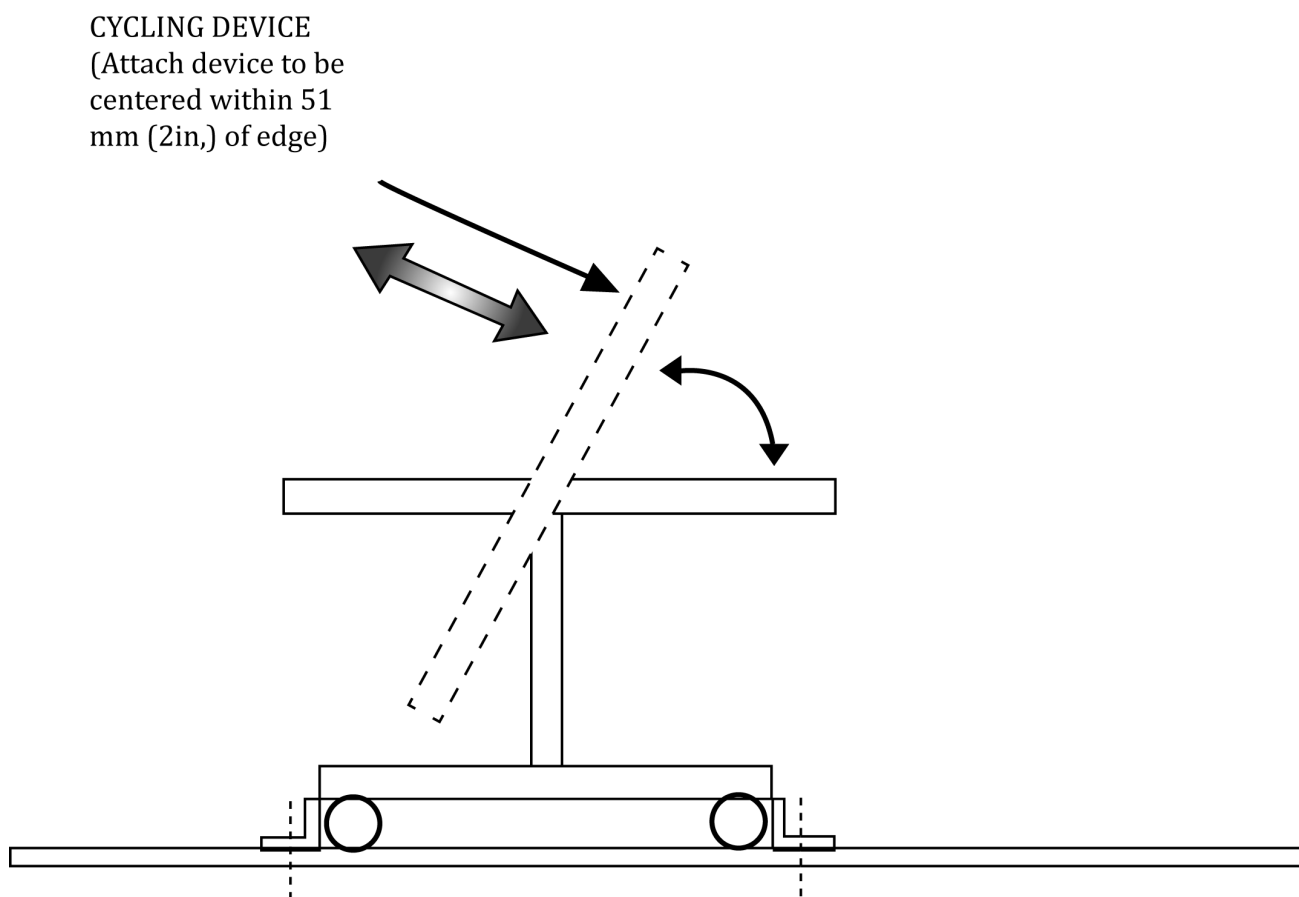

Figure 16 — Tilting Top Table - Cycle Test

10 Tilting Top Table - Latch Strength Test (See Figure 17)

10.1 Test Setup

- a) The desk/table unit shall be placed on a test surface/platform, leveled, and the table base shall be restrained against movement.
- b) The table top shall be placed in its in-use (horizontal or near-horizontal) position with its lock/latch mechanism engaged.

10.2 Test Procedure

10.2.1 Apply an upward force of 222 N 25 mm inward and at the center of the edge of the table top in the direction that would typically move the table top into its stowed position.

10.2.2 Move the tabletop to its stowed (vertical or most upright) position. With lock/latch engaged, apply a horizontal force of 133 N at the center of the edge of the table top in the direction that would typically move the table top into its in-use position.

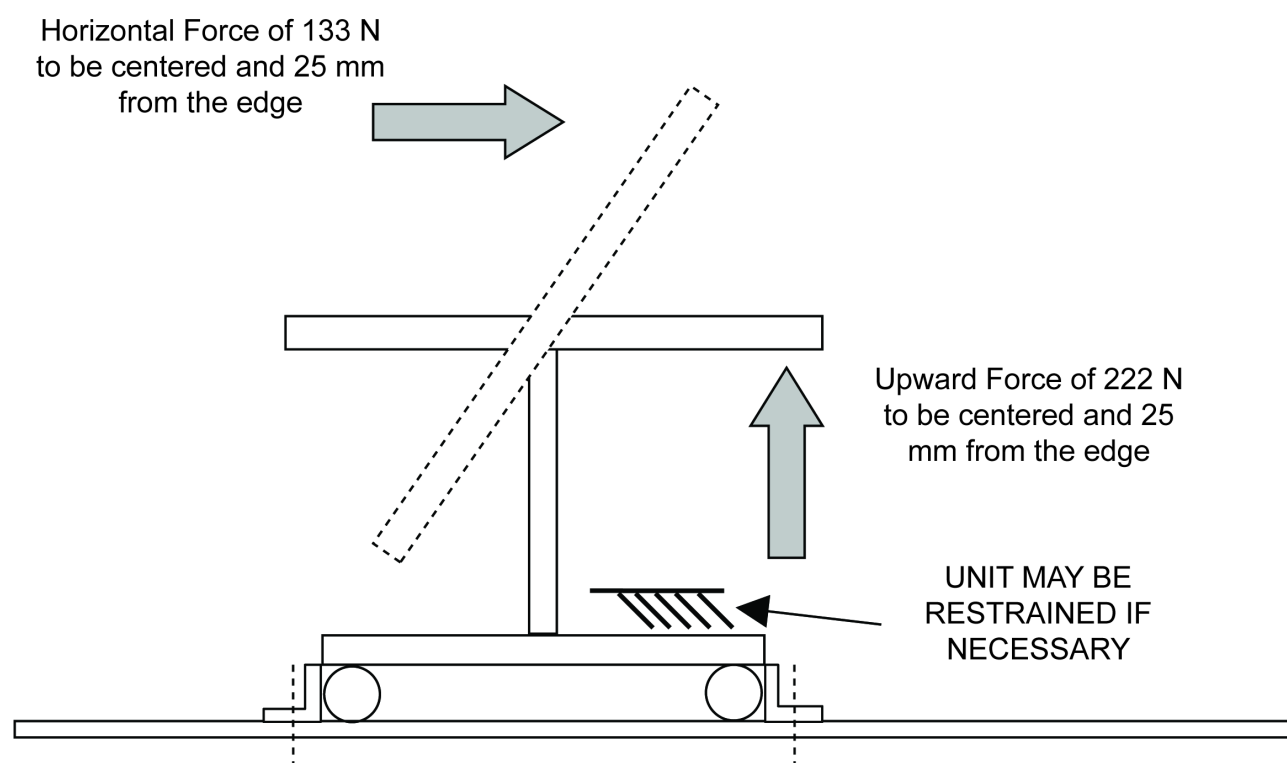

Figure 17 — Tilting Top Table - Latch Strength Test

11 Test Report Format

The test report shall include at least the following information:

- Name and address of the laboratory;
- Name and address of the laboratory, and the location where the tests were carried out, if different from the address of the laboratory;
- Unique identification of the report including an identification of each page and an identification of the end of the test report;
- Name and address of the client;
- Description and identification of the item(s) tested, e.g. product type and "name", photos etc.;

- f) Condition of the test item when received, e.g.: ready-to-assemble, mounted, defects etc.;
- g) Date of receipt of the test item;
- h) Date(s) of the performance of test;
- i) Identification of the test method(s) used; also report when temperature and relative humidity are outside the range. Any modification to the test method shall be technically justified and shall be recorded in the test report.
- j) The name(s), function(s) and signature(s) of the person(s) authorizing the test report;
- k) A statement that the results relate only to the items tested;
- l) Date of issue of the report;
- m) Test results with, where appropriate, a statement of compliance/non-compliance with requirements and/or specifications.

Annex A

(informative)

Recommendations

The suggested loads and forces are provided to allow specifiers the freedom to carry out the tests in the manner they consider preferable.

A.1 Principle

A range of loads, cycles, etc. are suggested in this annex to ensure that the standards will be of use where no requirements document is available or to assist in the development of one.

Users of these test methods should consider conducting all the tests on one sample. If more than one sample is used, the number of samples is to be noted in the test report.

The suggested loads, cycles, etc. are intended to ensure that specifiers may gain experience in the use of strength and durability standards, in a manner which will make it possible to compare the test results with those of other specifiers. For example, without any guidance, one specifier might choose to use a 250 N strength test and a durability test of 10 000 cycles. This would have no meaning to another specifier which had chosen to use a 100 N strength test and a durability test of 20 000 cycles.

The suggested loads, cycles, etc. should be sufficient to cover not only the full range of domestic and non-domestic applications but also the differences which will exist in the manner in which furniture is used in different applications. It should be noted that the loads and cycles which are appropriate to testing, e.g. the loads and cycles applied to a desk for general office use may be different from the loads and cycles that would be appropriate to table for use in a hospital, bank or home office.

It should be emphasized that test methods for activities affecting the safety of tables, have not been pre-selected from the range of strength and durability tests. If required they should be determined by the specifier, because the requirements for safety may be different from the requirements for serviceability.

The suggested ranges of loads, cycles, etc. are provided to allow specifiers the freedom to carry out the tests in the manner they consider preferable. It is not intended that the tests be carried out at the lowest test level and carried on, increasing in severity until failure occurs, nor that tests should be carried out at a pre-determined column, based on the application for which the furniture is intended.

The requirements must be determined by the specifier. The requirements used in other furniture standards include:

- no failure affecting the safe use of the product;
- no failure affecting function or appearance.

It is emphasized that the application of this International Standard is only useful if the requirements truly represent the service environment for which the furniture is intended.

A.2 General Requirements

The requirements should be determined by the specifier. However, the following is proposed:

The requirements should be considered as fulfilled when after testing in accordance with Table A.2:

- 1) there are no fractures of any member, joint or component,

- 2) there are no loosening of joints intended to be rigid,
- 3) table fulfills its functions after removal of the test loads,
- 4) table shall not overturn during stability tests
- 5) any deflection requirements if applicable shall be fulfilled
- 6) glass may break if in a safe manner (see definition for safety glass)
For unenclosed horizontal surfaces under 1118 mm in height, glass shall meet the requirements of ISO 12543-4:2011 Glass in building – Laminated glass and laminated safety glass – Part 4: Test methods for durability.

Post-test Assessment for 6.6.2

After the test, check the glass according to the following and record any damage:

- a) damage to glass
- b) glass that has become completely dislodged
- c) glass that has been broken by the impactor in one of the following manners:
 - c1) numerous cracks appear forming separate fragments with the sharp edges, some of which are large.
 - c2) numerous cracks appear, but fragments hold together and do not separate.
 - c3) disintegration occurs, leading to a number of particles, which are relatively harmless.

NOTE 1 Breakage type c1 is typical of annealed glass. Breakage type c2 is typical of laminated glass. Breakage type c3 is typical of heat toughened glass.

Assessment for 8.2

For motor driven units, if shutdowns (requiring a recalibration) occur more than 3 times per any given 500 cycle interval (not including up to three recalibrations at a set interval throughout the test if recommended by manufacturers instructions), the unit shall be considered as having a loss of serviceability.

NOTE 2 A “double button-push” describes having to repeat engagement / activation of the height controller within the time for one cycle and is not considered a shutdown, however no more than 25 “double button-pushes” is allowed in any given 500 cycle interval.

Table A.2 — Stability, strength and durability tests

Test		Ref.	Loading	Test Level			
				0	1	2	3
1.	Horizontal static load test	6.2	Test force, N:				
			Type 1	150	400	400	600
			Type 2	150	200	200	300
			minimum horiz.force, N	75	100	100	100
2.	Vertical static load on main surface	6.3.1	Test force, N				
			Type 1	300	750	1 250	1 250
			Type 2	150	750 (250 N if height > 600 mm)		
3.	Additional vertical static load test where the main surface has a length > 1 600 mm	6.3.2	Test force, N	500	750	1 000	1 000
			Cycles	10	10	10	10
4.	Vertical static load on end extension	6.3.3	Test force, N	100	200	300	300
5.	Horizontal durability test	6.4.2	Test force N				
			Type 1	150	300	300	300
			Type 2	150	150		
			Cycles				
			Type 1	5 000	10 000	15 000	20 000
Type 2	5 000	5 000					
6.	Stiffness of the structure Each of the calculated values shall be less than the specified displacement	6.4.3	D ₁ and D ₂ (measured in mm), divided by the maximal height of worktop (measured in m):	-	≤ 25 mm/m	≤ 17 mm/m	≤ 17 mm/m
			cycles:				
			Type 1	-	10 000	15 000	20 000
			Type 2	-	-		
7.	Vertical durability test-	6.5	cycles:				
			Type 1	10 000	10 000	15 000	20 000
			Type 2	-			
8.	Vertical impact test for glass tabletops	6.6.2	Drop height, mm:				
			- Safety glass				
			Type 1	-	180	180	180
			Type 2	-	140		
			- Other glass				
			Type 1	100	240	240	240
Type 2	100	180					
9.	Vertical impact test for all other tabletops	6.6.3	Drop height, mm:				
			Type 1	100	180	180	180
			Type 2	100	140		

Continues →

Test	Ref.	Loading	Test Level			
			0	1	2	3
10. Deflection	6.7	Per 6.7	-	L/100	L/180	L/240
11. Durability w/castors	6.8	Per 6.8	-	500 cycles	2000 cycles 3,2mm obstacle	5000 cycles 3,2mm obstacle
12. Drop test	6.9	Nominal drop height mm				
		- tables without glass	-	100	100	180
		- tables with glass	-	50	50	90
13. Leg Strength	6.10	Test forces determined by formulas in 6.10	-	-	formula	formula
14. Stability under vertical load test (the table shall not overturn with the test force)	7.2	Per 7.2	Per 7.2 except vertical load 20 kg	Per 7.2	Per 7.2	Per 7.2
15. Stability for tables with extension elements	7.3	Test force, N	Per 7.3	Per 7.3	Per 7.3	Per 7.3
16. Stability of tables designed to support a parasol	7.4	Per 7.4	Per 7.4	Per 7.4	Per 7.4	Per 7.4
17. Horizontal Stability Test for Tables with Castors	7.5	Per 7.5	Per 7.5	Per 7.5	Per 7.5	Per 7.5
18. Force Stability Test for Tall Products	7.6	Per 7.6	Per 7.6	Per 7.6	Per 7.5	Per 7.5
19. Durability of Height adjustment mechanism NOTE The above cycles and loads are considered minimum requirements and if manufacturers state cycle and load ratings greater than above, then those shall be considered for the testing.	8.2	Cycles	1 000	2 000	5 000	10 000
		Back edge load, kg	-	-	20	20
		Front load on disk, kg	-	25	30	30
20. Tilting Top Table – Cycle Test	9	Cycles	-	-	2 500	5 000
21. Tilting Top Table – Latch Strength Test	10	Upward Force, N	-	-	222	222
		Horizontal Force, N	-	-	133	133
** Adjust the table at its maximum height						

NOTE Static load test requirements are to be adjusted to 50 % of load requirements for fixed height units greater than 950 mm in height.

(-) if no value specified, then it is up to the specifier to determine if applicable and if so, the requirement.

A.3 TEST LEVEL IN RELATION TO FIELD OF APPLICATION

The following table can be used as a guide to the choice of Test Level in Table A.2.

Table A.3 — Test Level in relation to Application

Test Level	Field of Application
0	Careful Domestic Use / Delicate Table ^a
1	Domestic Use
2	General Non-Domestic Use
3	Severe Use

^a Careful Domestic Use / Delicate Table – table of light construction intended to be used only for placing lightweight objects, such as phones, flowers, magazines, lamps, etc.

Annex B
(informative)
Purpose and Applicability

Test No.	Test Title	Purpose	Applicability
6.2	Horizontal static load test	To evaluate the strength of the table when subjected to horizontal loading at the table top.	All tables
6.3	Vertical static load tests	To evaluate the strength of the table when subjected to vertical static loads.	All tables
6.3.2	Additional vertical static load test where the main surface has a length > 1600	To evaluate long table when an extra load is placed on it such as an extra person sits on it	All tables longer than 1600 mm
6.3.3	Vertical static load on end extension	To evaluate the strength of the end extension when subjected to short term vertical static loads such as perching/leaning or groceries, storage boxes, case of beer, etc.	End extensions
6.4.2	Horizontal durability test	To test the durability of the leg connection due to leaning on or moving the table	All tables
6.4.3	Stiffness of the structure	The purpose of this test is to evaluate the ability of a table to provide a surface that feels steady and does not oscillate while in use. This is done by applying a horizontal force to the table in each of four directions and measuring the amount the table surface	All tables
6.5	Vertical durability test	To determine the durability of the table when subjected to repeated vertical loading	This test is applicable for cantilever and pedestal tables only
6.6	Vertical impact test	To evaluate the strength of table tops during impacts	This test is applicable to tables and work surfaces
6.7	Deflection of table tops	To evaluate the deflection of loaded table tops when loaded over a period of time.	This testing does not apply to end extensions, single centre-supported tables, or tables with the longest unsupported dimension less than 900 mm.

Test No.	Test Title	Purpose	Applicability
6.8	Durability of tables with castors	The purpose of this test is to evaluate the ability of desks/tables with castors to withstand fatigue, stress, and wear caused by moving the product.	This test applies to tables that have castors fitted to all legs/supports. This test does not apply to keyboard/laptop tables.
6.9	Drop test	The purpose of this test is to evaluate the ability of the unit to withstand impact forces when lifted from one end and dropped.	This test is only applicable for tables weighing more than 20 kg and less than 136 kg
6.10	Table Top-to-Leg Assembly Strength test	The purpose of this test is to evaluate the ability of desk/table single leg to withstand handling or moving or striking an obstruction.	This test is applicable to units with legs
7.2.2	Stability under vertical load for tables that can be set to a height of 950 mm or less	The purpose of this test is to assure that the table will not overturn when a likely vertical load is applied to it, such as a person sitting on it or leaning/perching on it.	All tables
7.2.3	Stability under vertical load for tables that can be set to a height greater than 950 mm	The purpose of this test is to assure that the table will not overturn when a likely vertical load is applied to it.	Tables that can be adjusted to or be higher than 950 mm
7.3	Stability for tables with extension elements	The purpose of this test is to assure that the table will not overturn when a likely vertical load is applied to it.	Tables with extension elements
7.4	Stability of tables designed to support a parasol	The purpose of this test is to evaluate the table and its ability to resist wind blow-over.	This test does not apply to tables with parasols/canopies that do not derive their support from the table.
7.5	Horizontal Stability Test	The purpose of these tests is to evaluate the stability of the desk/table products to resist tipping during movement.	All tables
7.6	Force Stability Test for Tall Products	The purpose of this test is to evaluate the stability of tall desk/table products when subjected to horizontal forces.	This test applies to any unit that is higher than or can be adjusted to heights greater than 1067 mm. This includes tables that can be tilted up in a stowed position (flip top tables) that are taller than

Test No.	Test Title	Purpose	Applicability
			1067 mm when in the stowed (for storage) position. This test also applies to units with mechanically attached screen or storage segments that are greater than 1067 mm in height.
8	Height Adjustable Mechanisms	The purpose of this test is to evaluate the ability of user adjustable surfaces to be cycled through their range of adjustment under load.	<p>This test is only applicable to tables that are designed to be adjusted in height (both raising and lowering) by the user, when there is an additional load on a table, as specified in the requirements document.</p> <p>This test does not apply to pin adjustable (incremental adjustment) tables or adjustable keyboard support surfaces.</p>
9	Tilting Top Table – Cycle Test	The purpose of this test is to evaluate the tilt top table pivot mechanism and latching mechanism(s) (if present) for durability.	Tilting Top Tables
10	Tilting Top Table – Latch Strength Test	The purpose of this test is to evaluate the tilt top table lock/latch for strength.	This test applies to tilting top tables with locking/latching mechanisms that hold the top in their in-use and/or stowed positions.